



# DACUS

Future technology...  
...because the future is now



CATÁLOGO DE PRODUCTO  
PRODUCT CATALOGUE



# RESPONSABILIDAD MEDIOAMBIENTAL

## ENVIRONMENTAL RESPONSIBILITY

Dachs Electrónica contribuye positivamente al medio ambiente con su propio sistema de generación de energía eléctrica renovable.

Dachs Electronics makes a positive contribution to the environment with its own renewable electrical power generation system.



|  |       |   |       |
|--|-------|---|-------|
| About Dachs .....  | 2     | MOLEX: Sealed Connectors - Solid State Lighting.....        | 70    |
| LineCard .....   | 3     | MOLEX: Wire - To - Board.....                               | 68    |
| Environmental responsibility .....                         | 4     | MOLEX: Wire - To - Wire - Power Connectors.....             | 71    |
| ACP: Potentiometers .....                                  | 23    | MSI: Single Board Computer, Industrial Mother & Computer .. | 100   |
| ADLER Fuses.....   | 44    | NATCONN: Connectors.....                                    | 47-51 |
| AIMTEC: AC/DC Converters .....                             | 29    | NDK: Quartz Crystal.....                                    | 20    |
| APACOPTO: Optical Transceivers.....                        | 104   | OHIZUMI: Thermistors.....                                   | 34    |
| APEX: VR VIDEO.....  | 83    | PAIRUI: DC/DC Converters .....                              | 30    |
| APLEX: Industrial Panel PC .....                           | 82    | PAIRUI: LED Drivers.....                                    | 75    |
| BETTEL: Overcurrent Protection .....                       | 43    | PAIRUI:   |       |
| BRADY: Labels.....   | 102   | Transformers, Inductors, Ferrite Cores, Bobbins.....        | 31    |
| CLEC: Potentiometers .....                                 | 24    | RADIOCRAFTS: RF & Wireless Modules.....                     | 105   |
| COILMASTER: Inductors, Transformer, Ferrites .....         | 42    | RATIO ELECTRIC: EV Connectors and Chargers.....             | 80    |
| CHAMPTEK: Scanners and Modules .....                       | 92    | SAMBO: Cameras.....   | 93    |
| CHANG: Capacitors .....                                    | 16-17 | SCHRACK TECHNIK: Cam Switches.....                          | 78    |
| CHINMORE: Antennas .....                                   | 108   | TACHAI: Incandescent Lamps, Neon Lamps UVC LED .....        | 77    |
| CHUROD EUROPE: Relays.....                                 | 32    | TANCAP: Capacitors .....                                    | 15    |
| DECA: Switch and Pushbuttons.....                          | 74    | TDK-EPCOS: Aluminium Electrolytic Capacitors .....          | 9     |
| DEGSON: Terminal Blocks .....                              | 73    | TDK-EPCOS: Ceramic Capacitors .....                         | 8     |
| DEGSON: Communications.....                                | 101   | TDK-EPCOS: Ceramic Switching and Heating Components.....    | 11    |
| DENSITRON: Displays .....                                  | 87    | TDK-EPCOS: EMC Components.....                              | 8     |
| DEVETECH SOUND: Buzzers, Speakers, Electret .....          | 39    | TDK-EPCOS: Ferrites and Accesories.....                     | 10    |
| DEVETECH: Accessories, Antennas & Connectors.....          | 104   | TDK-EPCOS: Film Capacitors.....                             | 10    |
| DEVETECH: Adapters .....                                   | 95    | TDK-EPCOS: Inductors.....                                   | 12    |
| DEVETECH: Cables & USB Hubs.....                           | 96    | TDK-EPCOS: Power EMC Filters Chokes .....                   | 14    |
| DEVETECH: Enclosures.....                                  | 40    | Protection Devices: Varistors & Surge Arresters .....       | 13    |
| DEVETECH: Industrial Computers.....                        | 89    | TDK-EPCOS: Saw / RF Components and Modules .....            | 8     |
| DEVETECH: Light Indicators.....                            | 53    | TE CONNECTIVITY:  |       |
| DEVETECH: Lighting Control System .....                    | 76    | TE CONNECTIVITY: Connectors, Corcom filters.....            | 60-61 |
| DEVETECH: Metal Push Button Switches.....                  | 52    | TE CONNECTIVITY: Crompton Instruments.....                  | 62    |
| DEVETECH: Motors.....                                      | 94    | TE CONNECTIVITY: Electric Specialist.....                   | 56-57 |
| DEVETECH: Optoelectronics .....                            | 25    | TE CONNECTIVITY: Harnessing.....                            | 66    |
| DEVETECH: Power Film Capacitors .....                      | 27    | TE CONNECTIVITY: Identification and Labeling .....          | 64    |
| DEVETECH: Power Supplies.....                              | 91    | TE CONNECTIVITY: RAYCHEM:                                   |       |
| DEVETECH: TFT & Touchscreens.....                          | 88    | Medium and High Voltage .....                               | 65    |
| DEVETECH: Wireless Accesories, Antennas                    |       | TE CONNECTIVITY: Relay & Contactors.....                    | 58-59 |
| and Connectors.....  | 106   | TE CONNECTIVITY: Switches & Knobs.....                      | 28    |
| DEVETECH: Wireless Technology .....                        | 107   | TE CONNECTIVITY: Tooling.....                               | 63    |
| DIOTEC: Semiconductors .....                               | 26    | TESTEC: Monitors, Boxes, .....                              | 98    |
| ELO TOUCH: Touch Computers, Touch Monitors .....           | 90    | UNIOHM: Resistors .....                                     | 36    |
| GEYER: Quartz Crystal Technology .....                     | 21    | VINCOTECH: Power Modules .....                              | 38    |
| HARVATEK: Leds.....  | 41    | WALSIN:   |       |
| HDK HOKURIKU: Sensors, Resistors and Tactile Switches..... | 33    | MLCC, MLC, Safety Cap, Ceramic Disc Cap .....               | 35    |
| ICOP: Boards, Pannels, Storage .....                       | 99    | WEIDMÜLLER: PCB Terminals and Connectors                    |       |
| KHONS: Electric Charger .....                              | 79    | Surge arrestors, Terminal Blocks .....                      | 54-55 |
| MENTOR: Light Guides .....                                 | 18-19 | WINSSEN: GAS Sensors.....                                   | 337   |
| MOLEX: Board-To-Board.....                                 | 67    | WINSTAR: Displays and Modules .....                         | 84-86 |
| MOLEX: I/O Connectors - Memory Module Sockets.....         | 69    | YDLIDAR: Sensors .....                                      | 97    |
| MOLEX: Memory Card Sockets - Modular Jacks.....            | 72    | YXC: Quartz Crystal Technology Crystals .....               | 22    |

**ELECTRONIC COMPONENTS .....** 7 a 44

**ELECTRICAL COMPONENTS.....** 45 a 80

**SYSTEMS.....** 81 a 102

**WIRELESS.....** 103 a 108



# ELECTRONIC COMPONENTS



## EMC COMPONENTS

Data and Signal Line Chokes / Common-mode Filters

Power Line Chokes (EPCOS)

LCL Filters (EPCOS)

Power Line EMC Filters (EPCOS)

Output Filters (EPCOS)

EMC Filters for Shielded Rooms (EPCOS)

EMC Feedthrough Filters (EPCOS)

Sine Former (EPCOS)

Ferrites for EMC Suppression (TDK)

TDK Clamp Filters (Ferrite Core with Case) (TDK)

Noise Absorber (TDK)

3-terminal Filters (TDK)

TDK Chip Beads (TDK)

CarXield-Automotive Filter

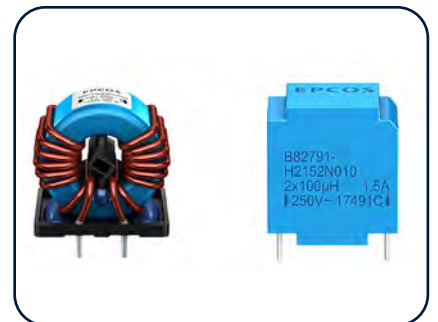

## CERAMIC CAPACITORS

Multilayer Ceramic Chip Capacitors

Dipped Radial Leded Ceramic Capacitors

Ultra High Voltage Ceramic Capacitors

3-Terminal Feedthrough MLCCs

Disc Type Leded Capacitors

CeraLink Capacitors

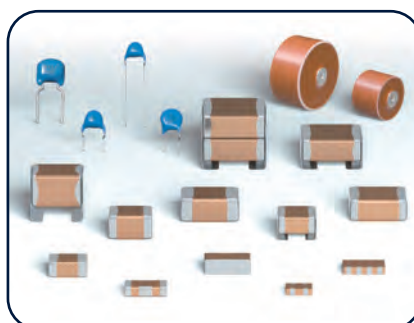



ALUMINUM ELECTROLYTIC CAPACITORS

Capacitors with Screw Terminals

Capacitors with 4-5-pin Snap-in Terminals and Solder Pins

Snap-in Capacitors

Large Size Capacitors

Axial-lead/Soldering Star Capacitors

Single-ended Capacitors

Capacitors for Pulse Applications

Hybrid Polymer Capacitors

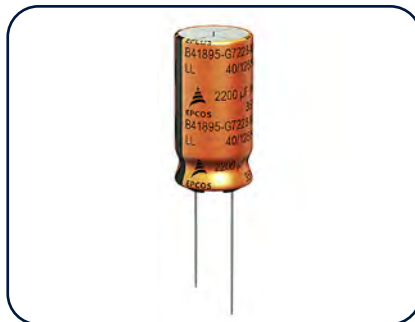

Filters

Diplexors & Triplexors & Baluns

Directional Couplers

Chip Antennas

Isolators & Circulators







FERRITES AND ACCESSORIES

- EFD/EV Cores and Accesories
- ER/ETD/EQ Cores and Accesories
- PM/P/P Cores Halves/EP Cores and Accesories
- PQ Cores and Accesories
- Ring/Double-Aperture Cores
- RM Cores and Accesories
- U/I Cores
- Blocks, Plates, Disks
- Ferrite Materials
- E/ELP Cores and accesories

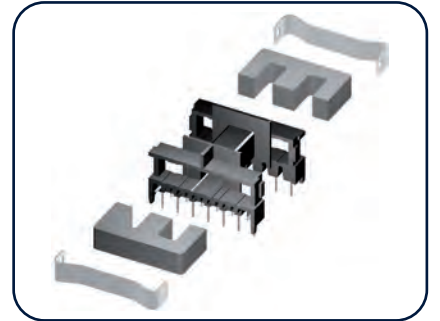

FILM CAPACITORS

- AC Film Capacitors incl. Motor Run
- Metallized Polyester Capacitors (MKT)
- Metallized Polypropilene Capacitors (MKP/MFP)
- EMI Suppression Capacitors
- Power Capacitors (EPCOS)

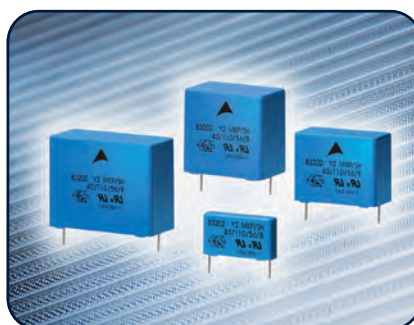



CERAMIC SWITCHING AND HEATING COMPONENTS / PIEZO COMPONENTS

High Voltage contactors PTC Thermistors for Motor Start (EPCOS)

PTC Thermistors for Switching Applications (EPCOS)

PTC Thermistors as Heating Elements (EPCOS)

Switching Spark Gaps (EPCOS)

Multilayer Piezo Actuators (EPCOS)

Ultrasonic Nebulizer Units (TDK)

Piezoelectric Receiver (TDK)

Electromagnetic Buzzers (TDK)

Piezoelectric Buzzers (TDK)

Chip NTC thermistors

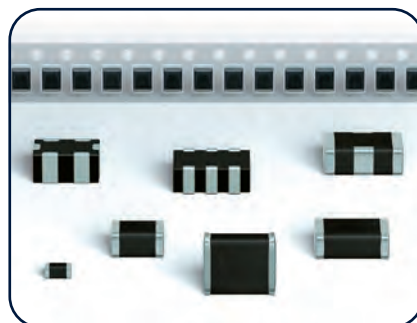
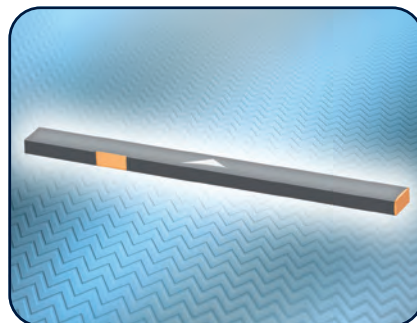



INDUCTORS (COILS)

- SMT Inductors (EPCOS)
- SMT Power Inductors (EPCOS)
- ERU Chokes (EPCOS)
- Transponder Coils
- Leaded Inductors (EPCOS)
- Inductor (Coils) (TDK)

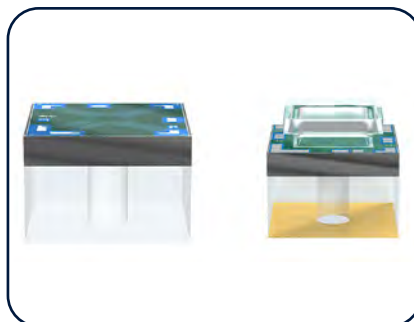
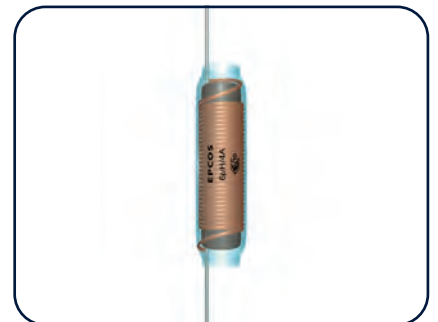
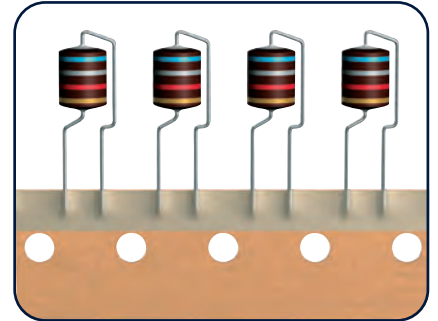

SENSORS AND SENSOR SYSTEMS

- MEMS Accelerometer
- Clamp AC current sensors
- NTC Temperature Measurement Sensors
- SMD NTC Thermistors (EPCOS)
- Level Sensors (EPCOS)
- Limit Temperature Sensors (EPCOS)
- Motor Protection Sensors (EPCOS)
- Pressure Sensor Elements (EPCOS)
- Pressure Sensor Transmitters (EPCOS)
- Current Sensors (TDK)
- Powder Level Sensors (TDK)
- Gear Tooth Sensors (TDK)
- Surface Potential Sensors (TDK)
- Humidity Sensors (TDK)
- Toner Concentration - Residual Volume Sensors (TDK)

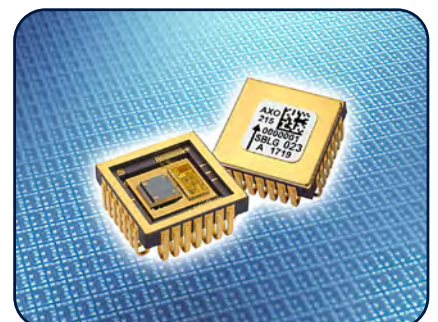

PROTECTION DEVICES  
VARISTORS & SURGE  
ARRESTERS

- Voltage Protection
- CeraDiodes
- Ceramic Transient Voltage Suppressors (MLV, SHCV Varistors)
- SMD Disk Varistors (CU)
- ThermoFuse Varistors
- Chip Varistors
- Ring Varistors
- 2 & 3 Electrode Arresters
- Arresters for AC/DC Power Line Protection
- Ultra Slim TVS Diodes

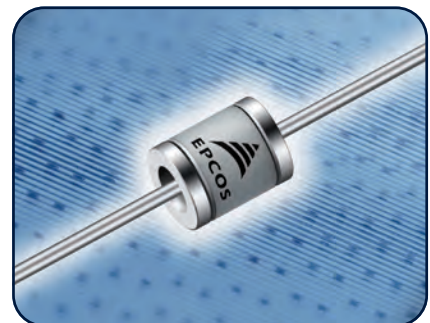
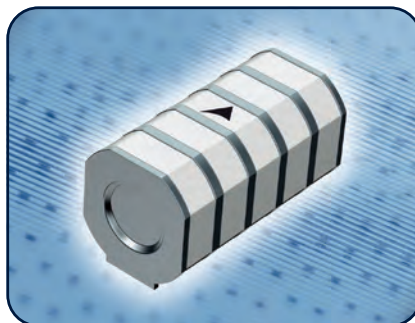

POWER EMC FILTERS

Filters for converters and power electronics

IEC Inlet filters

Filters for PCB mounting

Filters for installations and systems

SIFI-A/F for normal insertion loss

SIFI-C/D/H for high insertion loss

3-Line Active Leakage current Filter (LeaXield)



CAPACITORS

CA45 low ESR solid tantalum chip

CA45 solid tantalum chip capacitors

CA42 dipped tantalum capacitors CA Hermetically sealed axial tantalum

CA30 wet tantalum capacitors



## CAPACITORS

### Surface Mount Aluminium Electrolytic Capacitors - CHIP

- -55°C / 125°C
- Case Diameter 4-12.5mm
- Reflow soldering and high density surface mounting available



### Miniature Aluminium Electrolytic Capacitors - RADIAL

- -40°C / 105°C
- Ultra miniature / Standard / Low ESR / High reliability type
- Long Life (6khrs)/ Low ESR / Low Leakage current



### Conductive Polymer solid aluminium electrolytic capacitor

- RADIAL
- -55°C / 105°C
- Solid / Hybrid
- Long Life

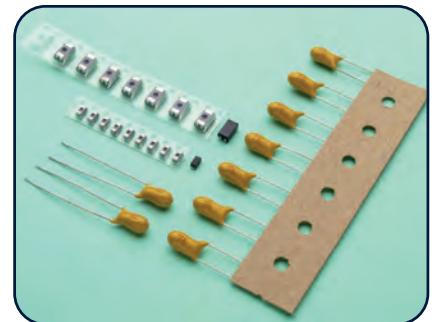

### Large Type Aluminium electrolytic capacitor -RADIAL

- -40°C / 85°C
- Snap-in / Screw
- Long Life







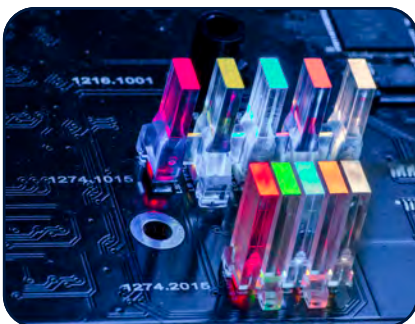
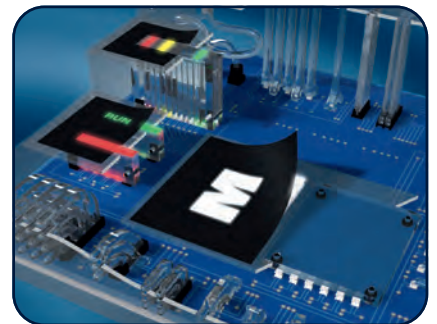
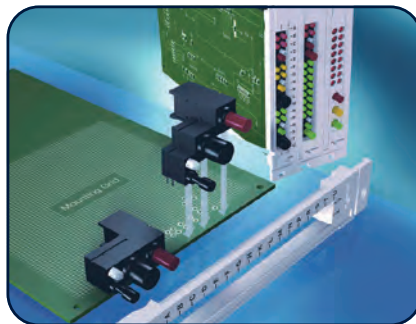
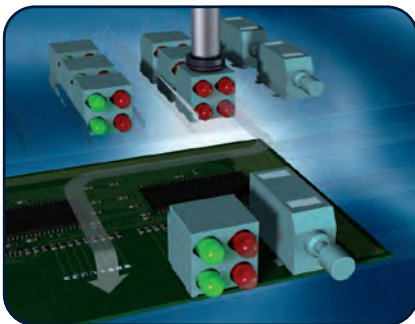
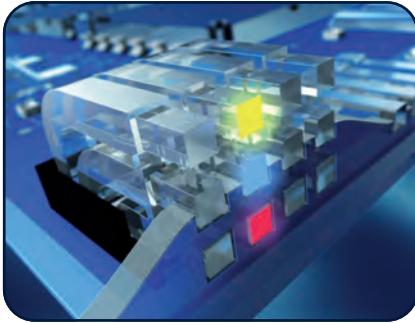

## LIGHT GUIDE SYSTEMS

Front Panel Light Guides /  
Horizontal&vertical light guides  
for mounting on circuit boards  
/ Flexible light guides/ Square  
light guides /

## KEYPAD COMPONENTS AND ACCESORIES

Electromechanical components  
SMD&THT

We realize your lighting ideas





### OPTOELECTRONICS

M-Fiber/Ring Lighting /Signal Light/Led display Systems (SMD & THT)/Surface Symbol illumination system/Holders/Reflectors/Area Lighting



### KEYPAD COMPONENTS

Pushbutton caps and signal indicators/ Plunger with point illumination/Customized solutions/SMD pushbuttons/7 segment displays



### ELECTROMECHANICS

Switches/Push button/fuse holders

### HANDLES

Plastic, aluminium, steel, stainless steel, tray collapsible and carrying handles



### KNOBS

Digital and analog turning knobs/plastic turning , wing pointer and adjusting knobs

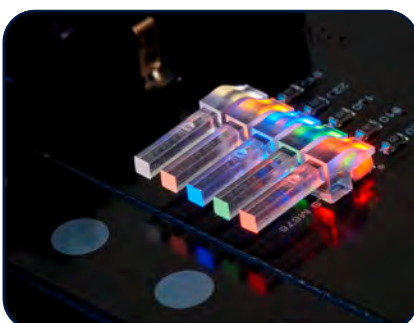
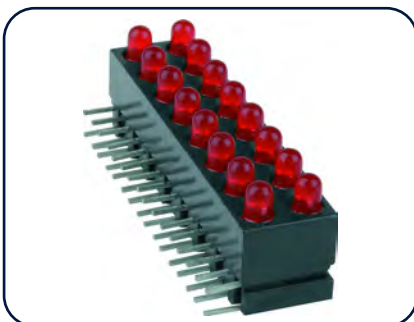



QUARTZ CRYSTAL TECHNOLOGY

CRYSTAL UNITS (SMD AND THT)

CRYSTAL CLOCK OSCILLATORS

SPXO (SIMPLE PACKAGE CRYSTAL OSCILLATOR)

TCXO (TEMPERATURE COMPENSATED CRYSTAL OSCILLATOR)

VCXO (VOLTAGE-CONTROLLED CRYSTAL OSCILLATOR)

VCXO (VOLTAGE-CONTROLLED SAW OSCILLATOR)

HIGH PRECISION OSCILLATOR

CRYSTAL FILTER

SAW DEVICE

SYNTHETIC QUARTZ CRYSTAL



QUARTZ CRYSTAL  
TECHNOLOGY

SMD QUARTZ FOR CRYSTALS  
(MHz)  
Frequency Range (8-300MHZ)

SMD TUNING FOR CRYSTALS  
(KHz)

THT CRYSTALS (MHz/KHz)

OSCILLATORS  
XOs, VCXOs, TCXO, VCTCXOs

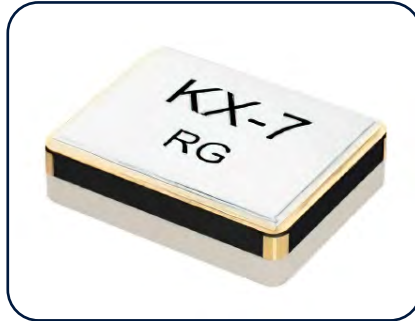

QUARTZ CRYSTAL  
TECHNOLOGY

CRYSTALS

KHz /MHz Crystals

OSCILLATORS

KHz / MHz Oscillators

TCXO / VCXO

Differential Oscillators

MEMS OSCILLATORS

Quartz MEMS oscillators

Low Power Oscillators

Low Jitter Oscillators

High Temp Oscillators

MEMS 32.768KHz

Differential Oscillators

AUTOMOTIVE GRADE

Automotive Crystals

Automotive Oscillators





POTENTIOMETERS  
(CONTROL AND TRIMMING)

SMD and Through-hole

-in carbon (CA), in 6, 9 or 14 mm

-cermet (CE), in 9 and 14 mm

CONTROL POTENTIOMETERS,  
MCA / MCE ROTARY  
SWITCHES, COM

Accessories: rotors, shafts,  
thumbwheels, gears, etc

ROTARY SENSOR, RS14

ENDLESS POSITION SENSOR  
360°, CS14

ANALOGUE SENSOR WITH  
32MM SIDE, AL32

ROTARY POSITION SENSOR,  
MRS14

ROTARY POSITION SENSOR:  
CA9 WITH GEAR SPECIAL

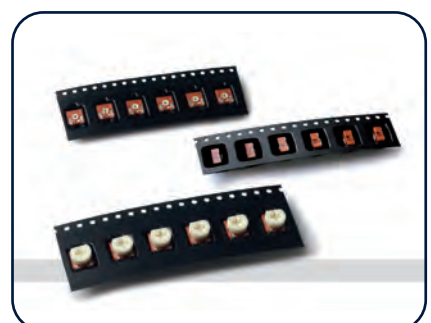
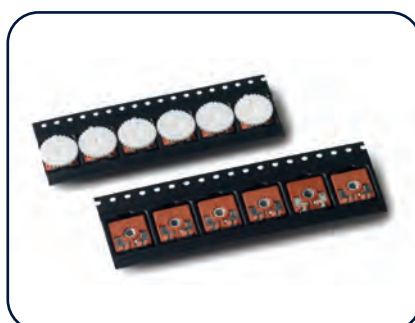

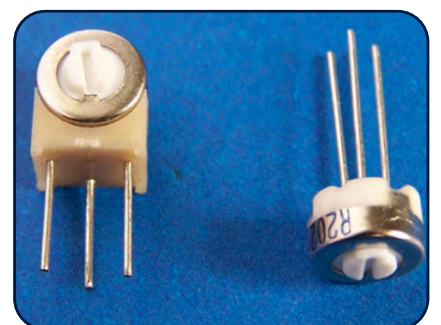
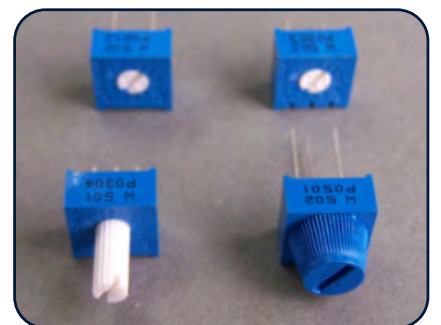
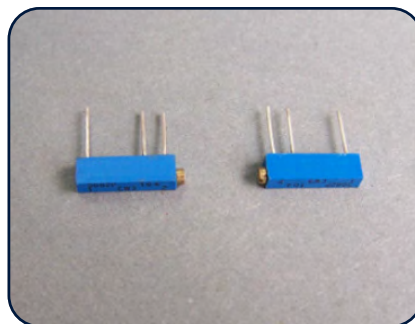
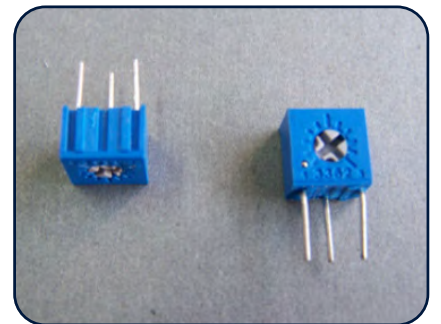
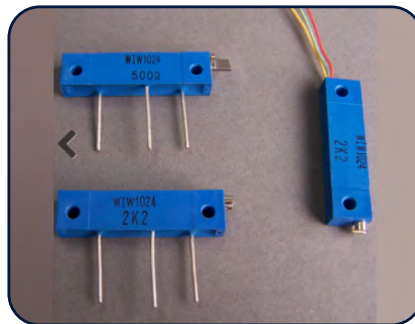

POTENTIOMETERS

Conductive Plastic Potentiometer

Trimmer Potentiometer

Wirewound Potentiometer

Hot-molded Potentiometer

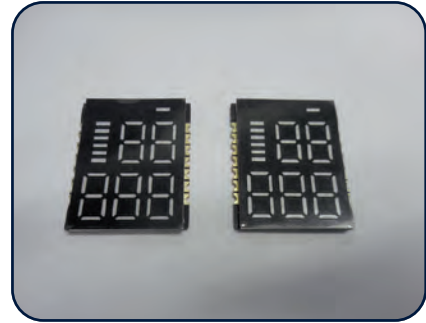

## OPTOELECTRONICS

### SMD LED

5050 3528 0805 0603 - Single Colour / Bi-Colour / Full colour (RGB) - High Luminance - Low current  $\leq 2.0\text{mA}$

### LED LAMP:

Choice of various viewing angles and color

Available on tape

Reliable and robust

Pb free

The product itself will remain within RoHS compliant version

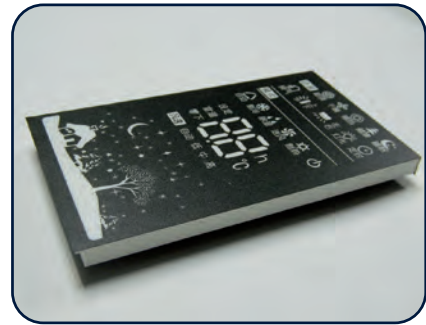

### LED DIGITAL DISPLAY:

Available for different size and digits

Low power consumption.

Pb free

The product itself will remain within RoHS compliant version



### SMD DISPLAY

Packaged in tape and reel for SMT manufacturing.

Design flexibility (common cathode or anode, digital or graphic).

Categorized for luminous intensity. The thickness is thinner than tradition display.

Pb free.

The product itself will remain within RoHS compliant version.

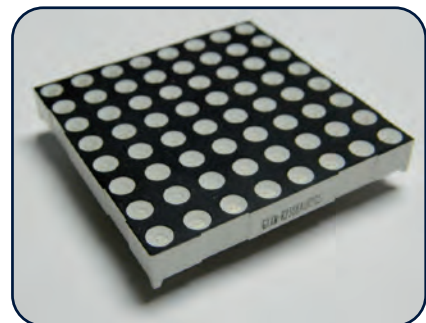

### LED Dot-matrix Display:

Large emitting dot different diameter

Low power/high brightness.

Pb free

### CUSTOMIZED PRODUCTS

Available for all customized design

Available for through hole type and SMD type

Low power consumption.

Pb free

The product itself will remain within RoHS compliant version





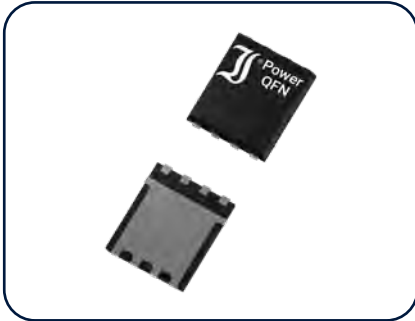

## SEMICONDUCTORS

Standard rectifiers

Fast switching rectifiers

Ultrafast switching rectifiers

Superfast switching rectifiers

Schottky Barrier Diode

Zener diodes

Transient Voltage Suppressor diodes

Current limiting diode

Small Signal Diodes

Bridge rectifiers, single phase

Bridge rectifiers, three phase

High voltage rectifiers

ESD Protection diodes

Bipolar Transistors and digital transistors

Field Effect Transistors

Diacs

MOSFET (Field Effect Transistors)

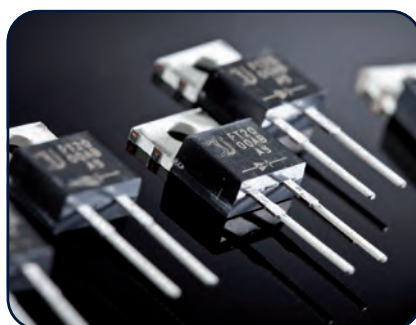
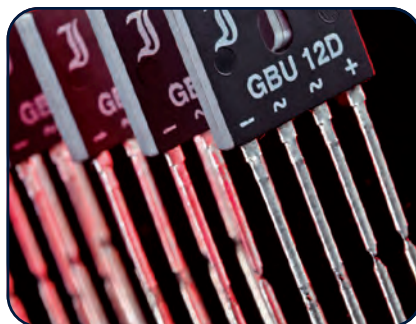

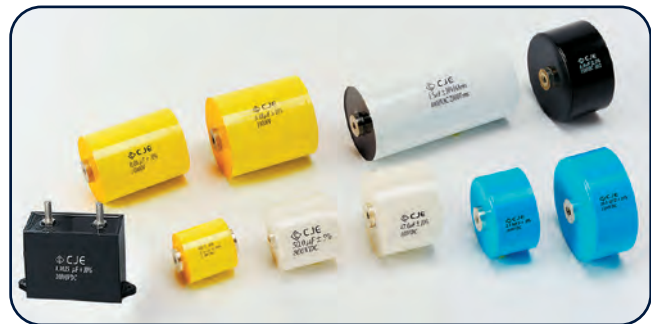
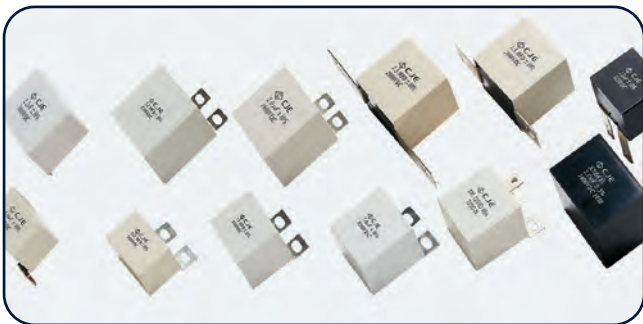

POWER FILM CAPACITORS

- Power Electronics
- Snubber Clamping Capacitors especially used for G.T.O&thyristors
- Super-High-Voltage Metalized Film Capacitors
- DC Filtering Metalized Film Capacitors
- Snubber Capacitors Especially used for IGBT
- AC Filtering Metalized Film Capacitors
- Automotive Capacitors
- Metalized Film Resonant Capacitors
- The snubber Capacitors Especially used for IGBT

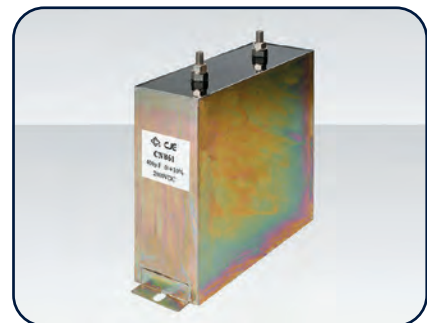

## SWITCHES & KNOBS

Emergency Stop Switches

Accessories & Hardware

DIP Switches - Rotary

DIP & SIP Switches-Standard

Ethernet Switches, Media  
Converters & Device Servers

Gemini Rocker/Paddle  
Switches

Gemini Toggle Switches

Industrial Panel Mount  
Switches & Lights

Keylock Switches

Knobs

Power Rocker Switches

Power Toggle Switches

Programming Jumper Plug  
Assemblies

Pushbutton Switches

Pushwheel Switches

Rocker/Paddle Switches

Rotary Switches

Slide Switches

Snap Action Switches

Tactile Switches

Toggle Switches



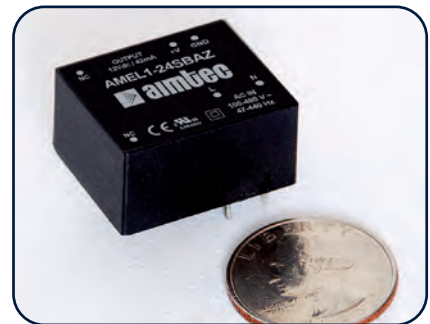

AC/DC and DC/DC converters

Small footprint, high density, wide input range

DC/DC ISOLATED

AC/DC CONVERTERS

SWITCHING REGULATORS

AC/DC LED DRIVER

DC/DC LED DRIVER

AC Adapters

EMC Filters

Common mode choke





DC/DC CONVERTERS-  
ENCAPSULATED

SIP Package 1~3W

DIP24 Package 3~6W

DIP1"X1" Package 3~15W

DIP2"X1" Package 20~30W

DIP2"X2" Package 40~50W

Non-Isolated 6~12W

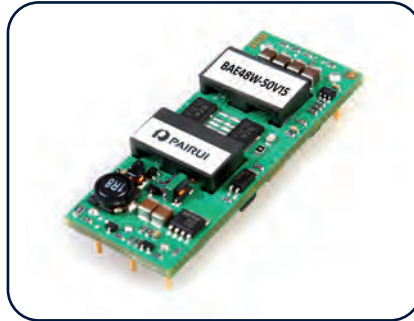

DC/DC CONVERTERS-  
BRICKS

1/16 Brick ~30A/~60W

1/8 Brick ~30A/~150W

1/4 Brick ~50A/~300W

1/2 Brick ~60A/~300W

FULL Brick ~60A/~700W

Non-Isolated ~16A/~100W



AC/DC converters ASQ  
series

Compact size, High power  
density / Universal Input  
voltage range

(85-264Vac/120-370Vdc)



TRANSFORMERS,  
INDUCTORS, CORES,  
BOBBINS

TRANSFORMERS

- Encapsulation Transformer
- Power Ferrite Transformer
- Audio Transformer
- Telecom Transformer
- Current Transformer
- Linear Transformer
- Toroidal Power Transformer
- Planar Transformer



INDUCTOR

- SMD Inductor
- Through-hole Inductor
- EMI Filter
- CMC Inductor
- Color Code Inductor
- Frame Core Chokes



CORES

- Ferrite Core
- Iron Powder Core
- Alloy Powder Core
- Amorphous Powder Core
- EMI Core



BOBBINS

- DIP Bobbin
- SMD Bobbin
- Clamp
- Encapsulation bobbin & case



- Automotive relays
- Industrial relays
- Alternative Energy relays
- Appliances relays
- Battery pressure sensor
- Latching Contactor



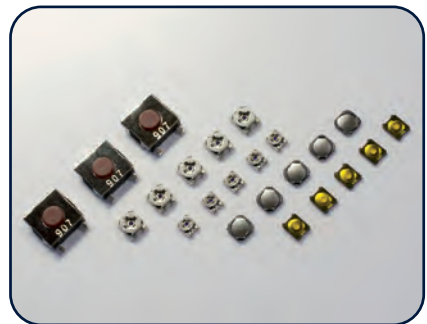
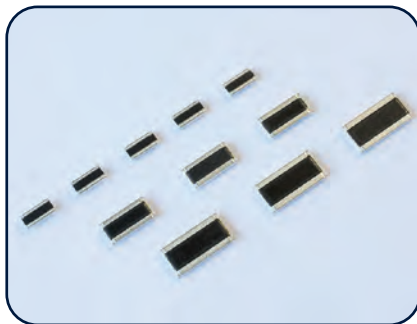
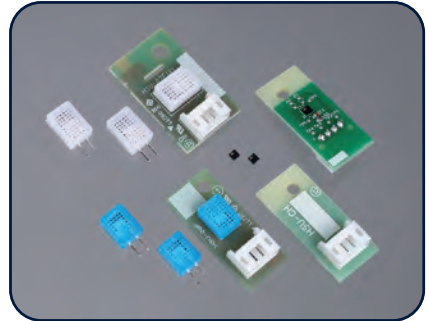
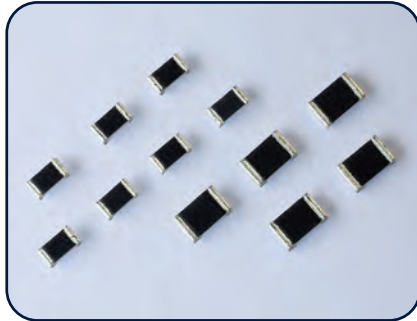
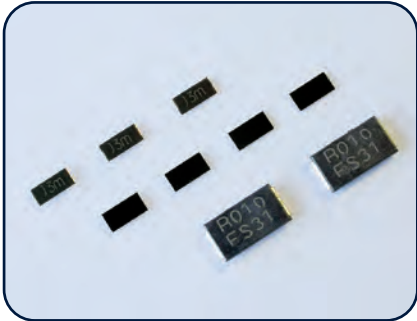

HOKURIKU SENSOR  
INNOVATION

Sensors

- Pressure Sensors
- Humidity Sensors
- Force Sensors
- 3-Axis Acceleration Sensors

High Frequency Components

Chip Fixed Resistors

Variable Resistors

Encoder

Circuit Modules

Piezoelectric Products

Fixed Resistors

Tactile Switches

Printed Circuit Board

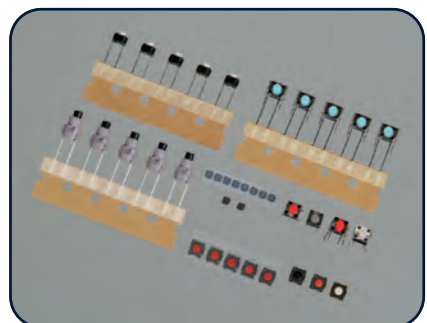
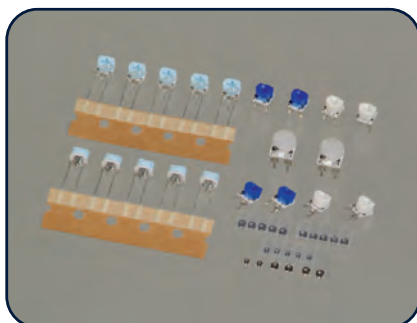
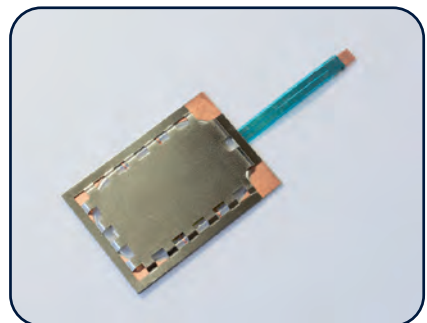
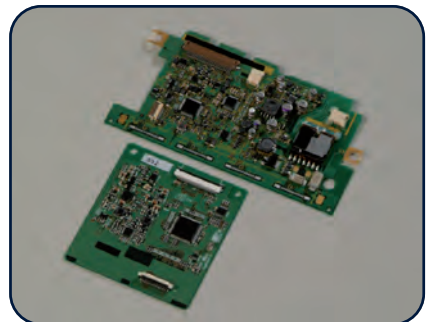
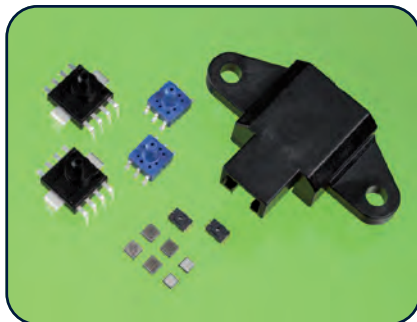



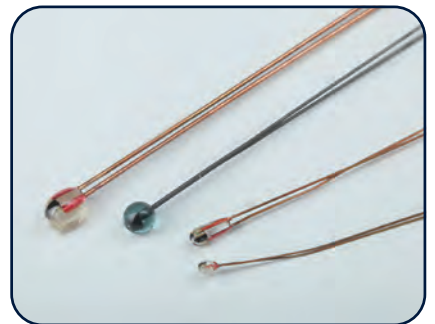
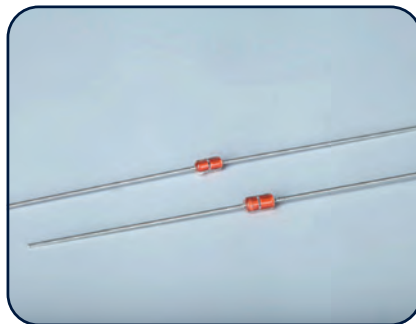

## THERMISTORS

High heat-resistant and durably glass-sealed Thermistors (NGR Series)

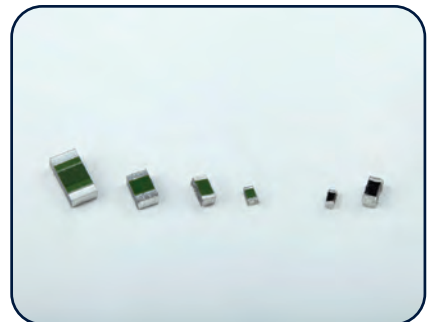
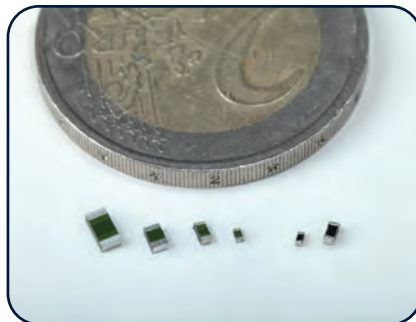

Thermistors Highly Heat-resistant Axial and Lead (NDH Series)

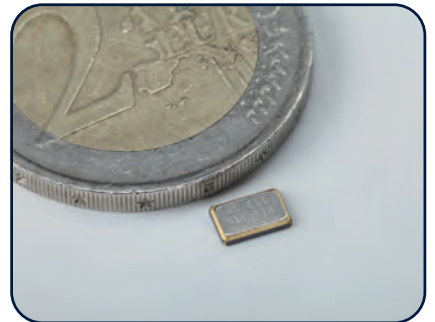

High Heat resistant lead-free Thermistors (NGH Series)

High Quality Epoxy-Coated Thermistors (NRC Series)

General Purpose and SMD Type (NSM Series)

High Precision and heat-resistant SMD Chip type (NSS Series)

Radial Lead Disc Thermistors (NRD Series)

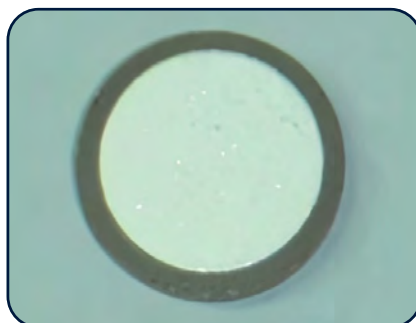

Thermistors / PTC Series

MLCC

General Purpose

Middle & High Voltage 200V to 3kV

Ultra-Small

Low Inductance

High Q / Low ESR HH Series

Microwave RF Series

Low Profile

Open Mode

Safety Certificated X1/Y2 S2

Series X2/Y3 S3 Series

Low Distortion

Automotive AEC-Q200

Soft Termination

Cap Arrays

MLC RADIAL LEAD CAPACITORS

SAFETY CAP

AH, AS Type: Class X1/Y1

AC Type: Class X1/Y2

CERAMIC DISC CAP

Class I 50V, 100V, 500V, 1KV, 2KV, 3KV, 6KV, Temperature Compensation

Class II 50V, 100V, 500V, 1KV, 2KV, 3KV, Hi-K Type

1KV, 2KV, 3KV Low Dissipation LB, LR Type

Class III Semi-Conductive Type

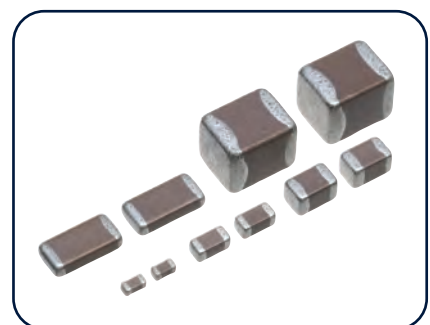
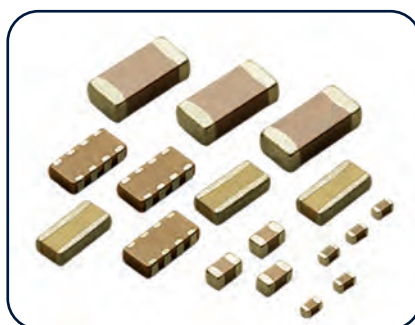
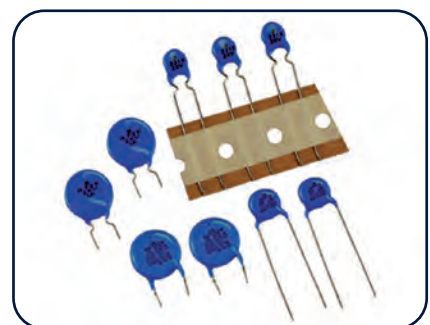
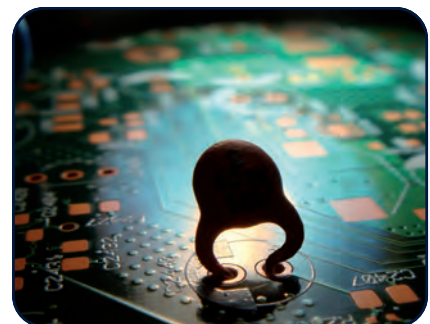
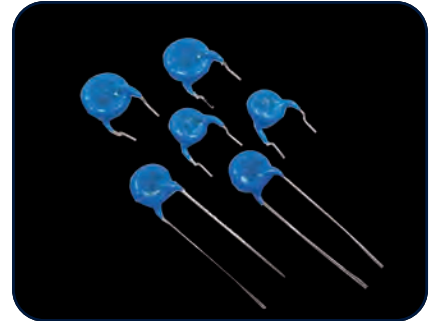
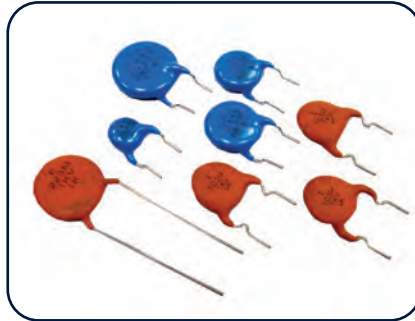



UNIOHM RESISTORS

SURFACE MOUNT  
CATEGORY

Chip Resistors

Thick Film

Thin Film

Current Sensing

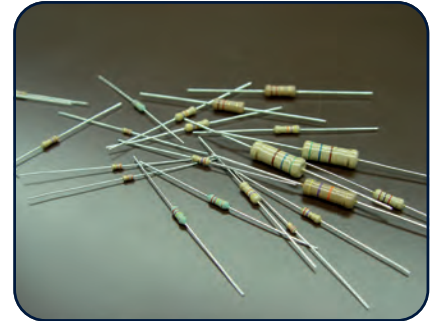
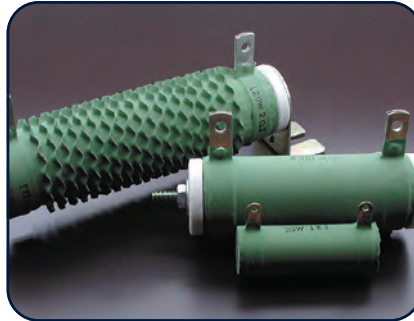

COATED & NETWORK

Carbon Film

Capacitor Network

Carbon Film Power

Current Sense

Current Sense Spring

Fusible

High Power

Metal Film Power

Panasert Type

Wire-wound Fusible

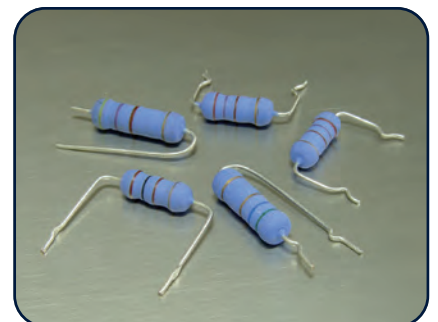
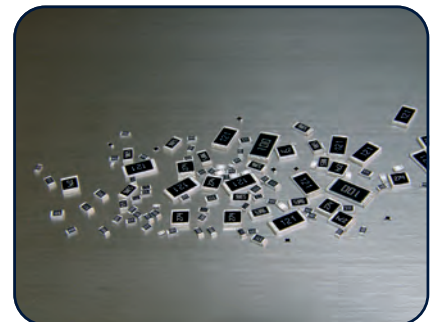
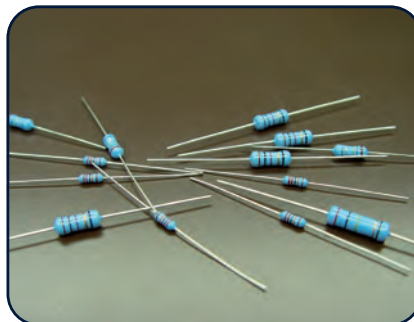

CEMENT

Cement Fixed

Columnar Type

Power Flat Alloy

Standard Packing

Ultra-Low Value

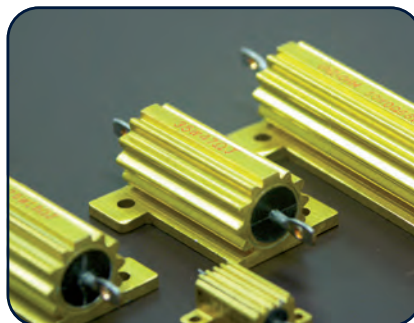

POWER TYPE

Bilateral Cement Fixed

Wire-wound Power



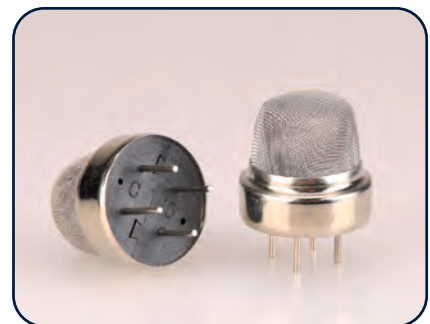
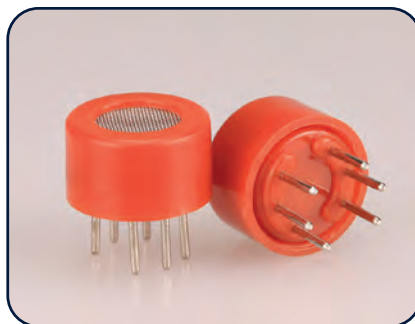
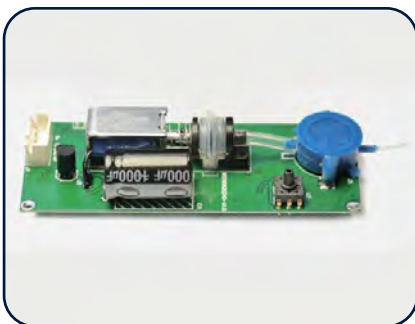
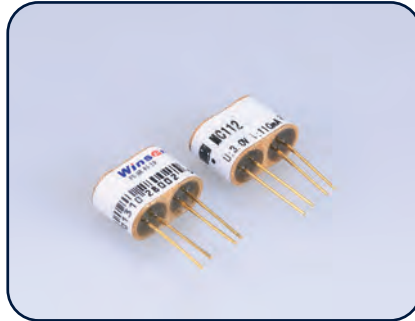

SENSORS AND SENSOR  
MODULES

Gas Sensors (IR, VOC, O<sub>2</sub>, O<sub>3</sub>, SO<sub>2</sub>, H<sub>2</sub>S, H<sub>2</sub>, CO, C<sub>2</sub>H<sub>4</sub>, refrigerant)

Flow Sensor , Temperature  
& Humidity Sensor,  
PressureSensor.

Customized module solutions



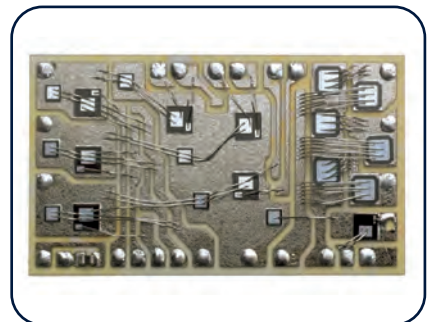

## POWER MODULES

Brake resistors

Efficient, compact, low inductive Power Modules

For motor drives, solar inverters, chargers, UPS...

IGBT, MOS, SiC chips for:

- 2 levels, multilevel
- Rectifiers, boosts, PFC
- Half bridges, H bridges, 6 packs, IPMs

Custom designs

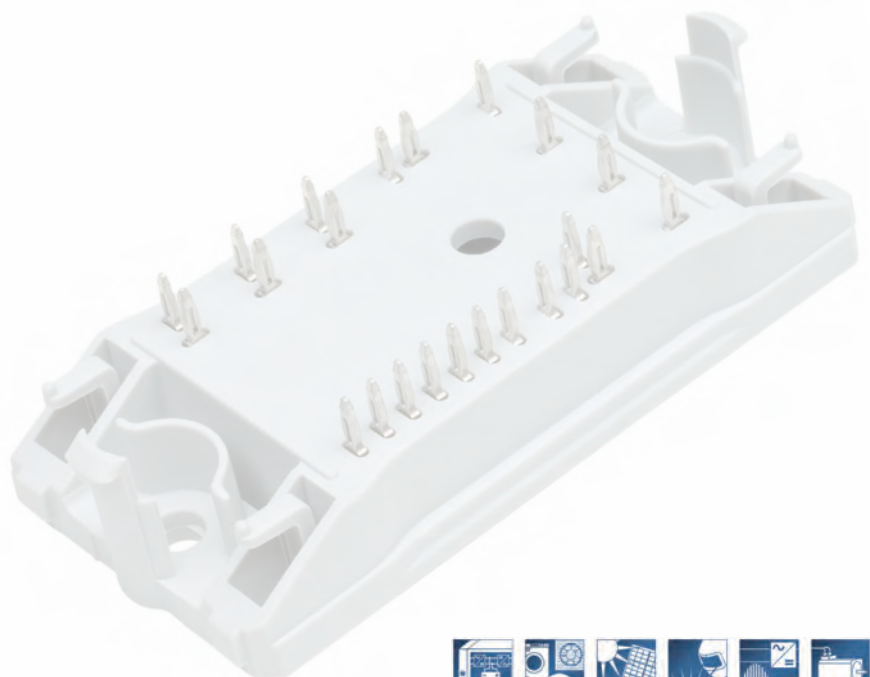

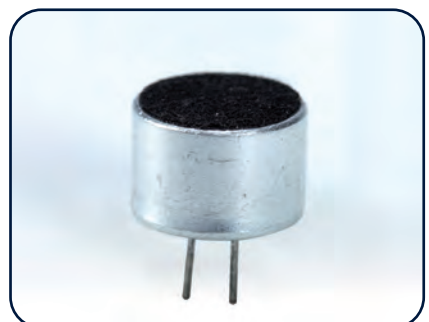
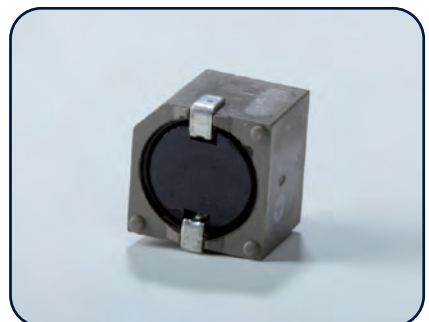
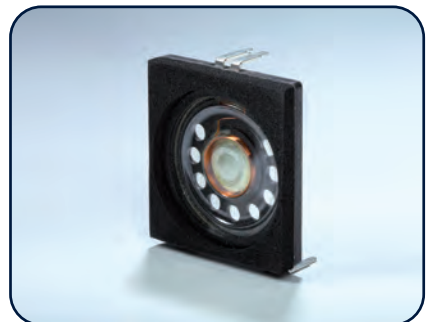
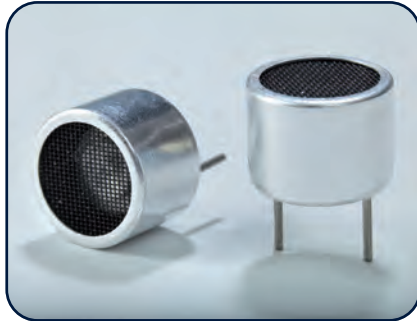
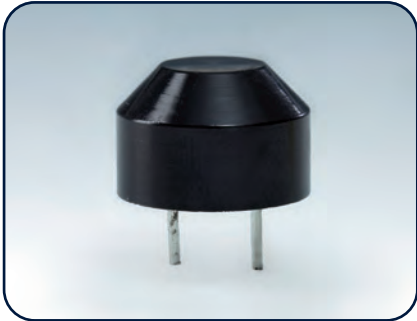

DEVETECH SOUND

Loudspeaker - Alnico Type

Loudspeaker - Ferrite Type

Ipod Speaker

TV Speaker

Mylar Speaker- Metal Frame

Mylar Speaker - Plastic Frame

Notebook & Modem Speaker

Tweeter

Dynamic Receiver

Dynamic Microphone &  
Speaker + Receiver

Electret Condenser  
Microphone

Ultrasonic Sensor

Piezo Ceramic Buzzer Plate

Piezo Buzzer, Magnetic / SMD  
Transducer & Siren

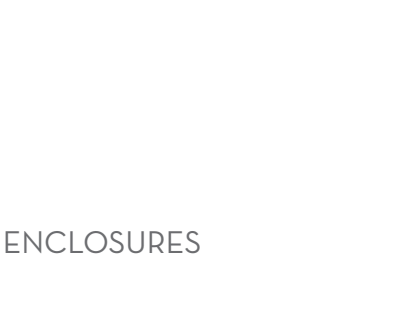
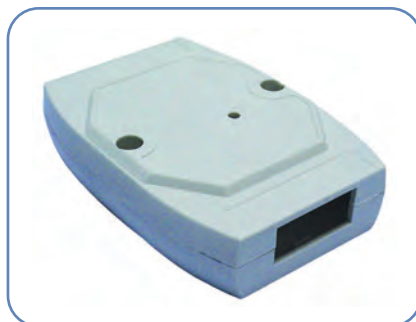

ENCLOSURES

Water Proof Enclosures

Hand-held Enclosures

Aluminium Extrusion Cabinet

Electric Conjunction Enclosures

Standard DIN-RAIL Enclosure



VISIBLE LED

- THT LED lamp
- SMD PCB Chip LED
- PLCC LED
- Customized LED Modules

INVISIBLE LED

- Infrared LED

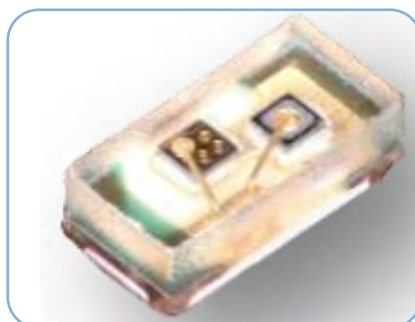
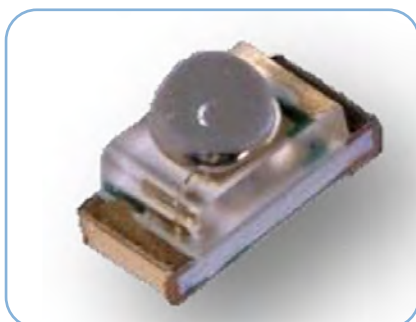
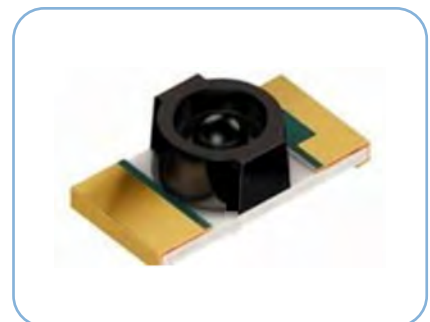





INDUCTORS & TRANSFORMERS & FERRITES

- Surface Mount Inductors
- Automotive Grade Inductors
- High Current Power Inductors
- Common Mode Choke
- Leaded Power Inductors, radial inductors.
- Shielded Radial lead Power Inductors
- Wire Bounds Inductors
- EMI Suppressions
- Through Hole RF Chokes, Axial Inductors
- High Frequency, Telecom, Flyback Transformer
- Ferrite Beads

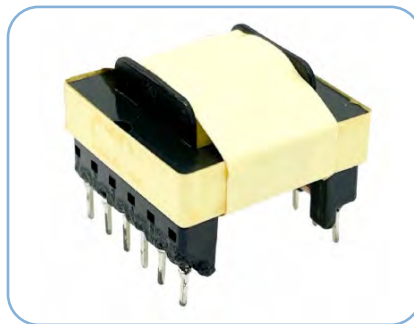
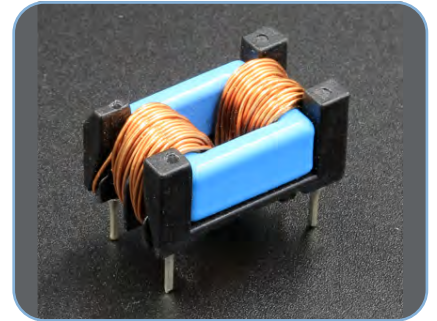

**-OVERCURRENT PROTECTION**

- SMD Fuse Series
- 2mm Fuses
- 3mm Fuses
- 5mm Fuses
- 6mm Fuses
- 7mm Fuses
- 9mm Fuses

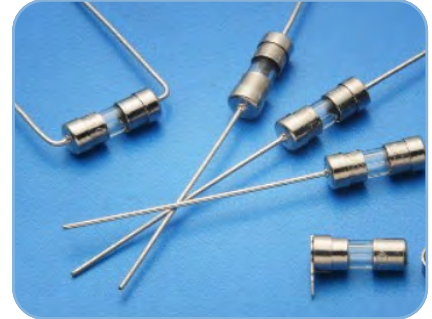

- Surface Mount Resettable
- Radial Lead Resettable

**-OVERVOLTAGE PROTECTION**

- ESD Suppressors

**-THERMAL PROTECTORS**

- Thermal Fuse Series
- Thermostat Series



**-FUSE ACCESSORIES**

- Terminal
- Fuse Clips
- Fuse Holders
- Panel Holders

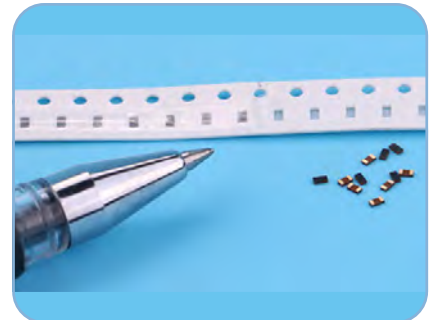
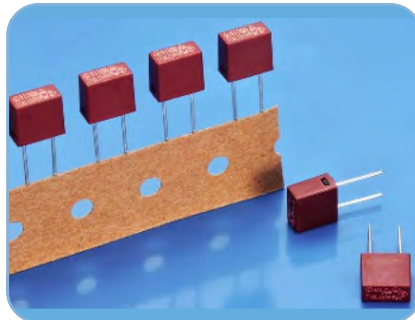

**-MULTIPLE PROTECTION**

- BTU Series

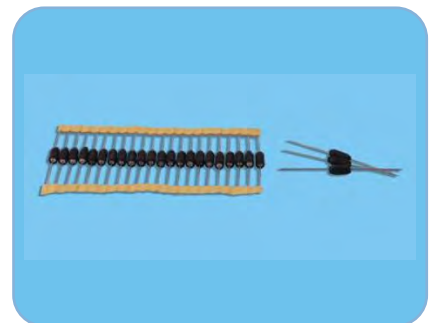
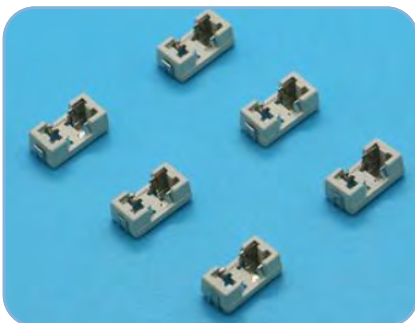

Electric Vehicle and Charging  
Equipment Protection

Automotive EV fuses

Photovoltaic fuses

Circuit protection Photovoltaic  
system

Surge protection

Energy storage system

Industrial power fuses



# ELECTRICAL COMPONENTS



Authorized Distributor



THE LOGISTICS PLATFORM  
FOR THE CONNECTIVITY ELECTRIC COMPONENTS

# 25 YEARS WORKING TOGETHER

REPACKAGING ACCORDING TO  
ELECTRICAL DISTRIBUTION CHANNEL

24 h Delivery  
Technical Support  
Flexibility



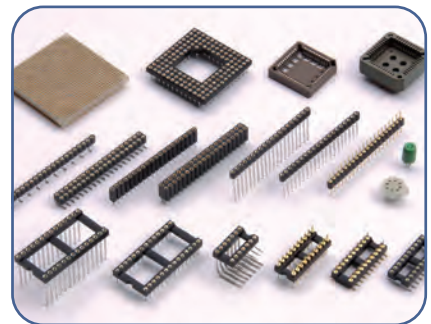
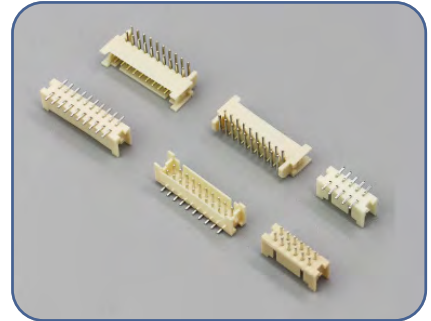
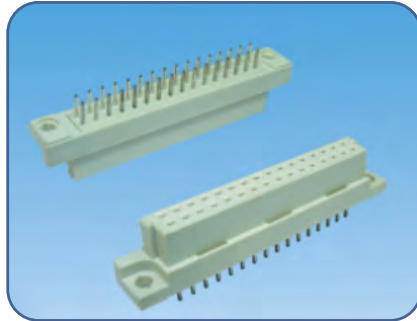
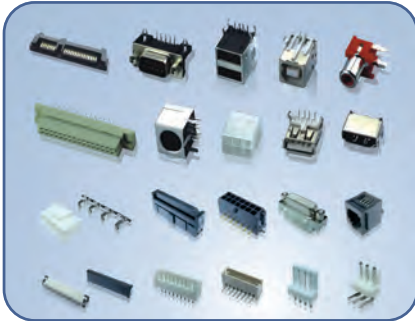

## CONNECTORS

Sockets & Machined Adapters

Pin Headers & Female Headers

Wafer Series

CABLE Series

Pin Headers & Female Headers



Micro-Match Connectors

Power Connectors

Hybrid Signal and Power Connectors

Floating Connectors

Battery Connectors.

Terminal block

Energy Storage Connectors

Electric Vehicle Connectors

Anderson Power Connectors

NEMA connectors

Pogo Pin Connectors

Heavy Duty Connectors

D-Sub Connectors

Assembled Cables

Custom Assembly Cables

Stamped, Turned Pins, Plastic Parts.

Design and development of  
Molds

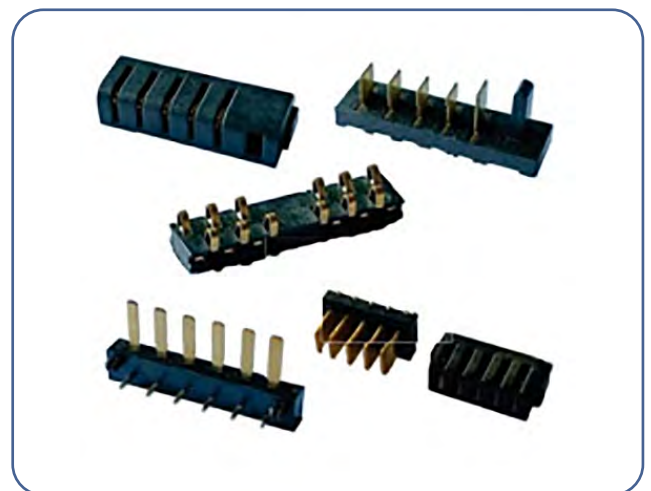
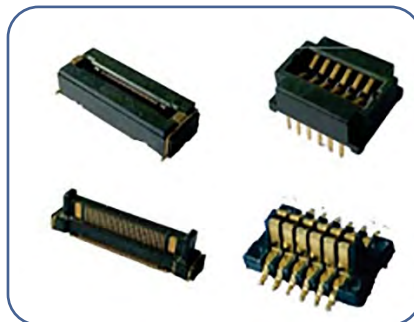
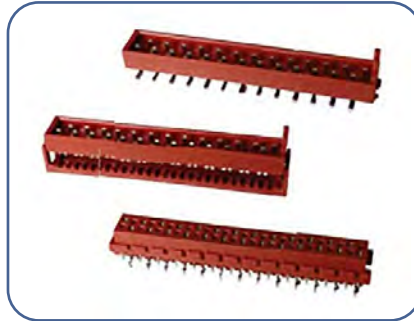

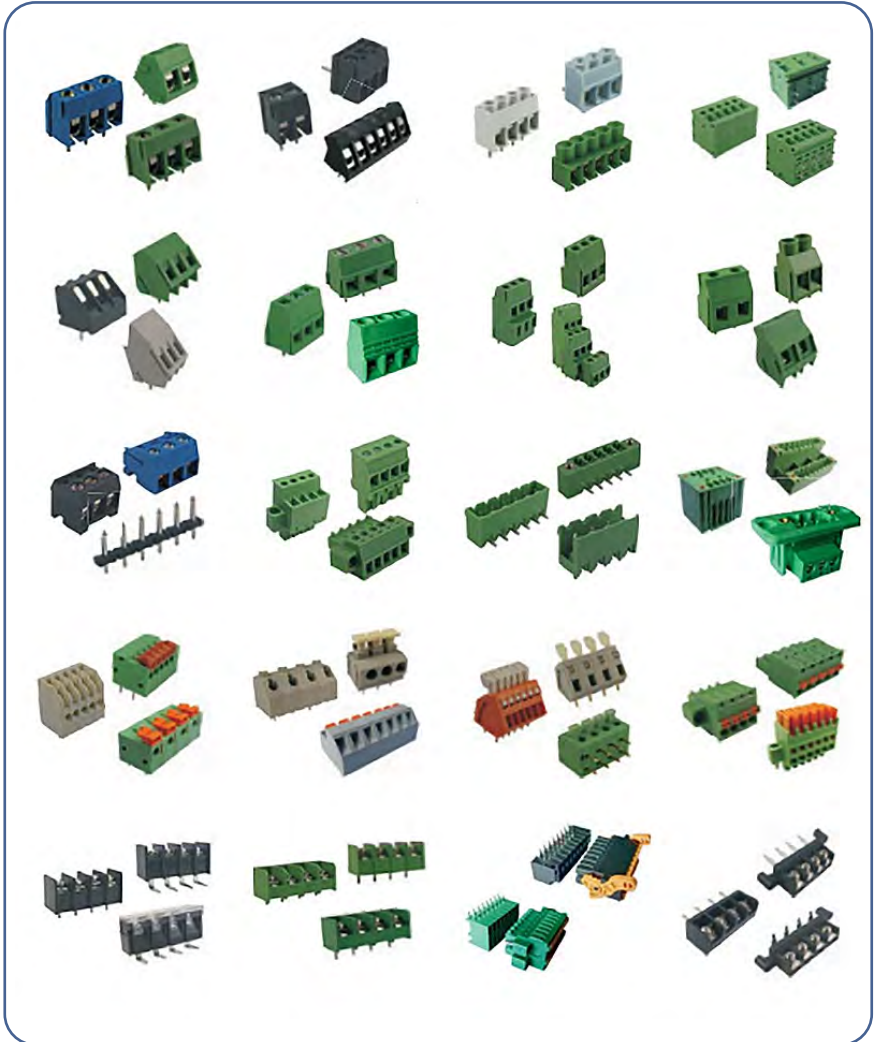





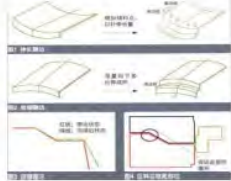



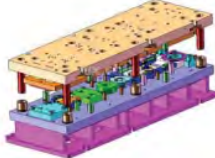

- ◀ Dynaform analysis
- ▶ 3D Mold Design
- ▼ Metal mold manufacturing



- ◀ Moldflow analysis
- ▶ 3D Mold Design
- ▼ Plastic mold manufacturing

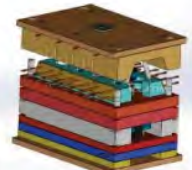







natconn®

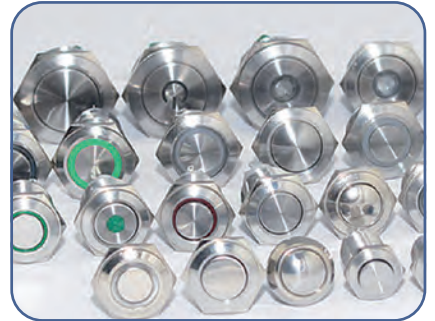



### DEVETECH METAL PUSH BUTTON SWITCHES

Install Diameter: 12mm, 16mm,  
19mm, 22mm, 25mm, 28mm,  
30mm

Led Voltage: 3V 6V 12V 24V  
110V 220V 380V AC/DC  
various voltage

Led Color: Red, Yellow, Blue,  
Green, White, Orange, Purple,  
and others. Double-color LED  
under request

Function: Momentary / Latching

Materials: Stainless Steel, Nickel  
Plated Brass and Zinc alloy.

Plated gold under request

Shape: Flat, High Flat, Arc  
button.

Pin Type: Screw terminal and  
Solder pin.

Protection Level: IP65, IP67,  
IK08, IK10





### INDICATOR LIGHT FEATURES

Connection type: With cable,  
Pins

Install way: Screw thread,  
Flushbonading

LED type: A grade, General,  
Dual-core

Hole diameter: 6mm, 8mm,  
10mm, 12mm, 14mm, 16mm,  
22mm

Color: White, Red, Green,  
Yellow, Blue, Dual-color

Materials: Plastic, Metal (Brass  
plated Nickle or Chromium)

Voltage: 12V, 24V, 36V, 48V,  
110V, 220V AC/DC (2V~750V)

Protection Level: IP65, IP67

Withstand voltage: Plastic  
(2000v), Metal(1700v)



## PCB TERMINALS AND CONNECTORS

### OMNIMATE Signal PCB: Terminals & Connectors

#### Terminals

Application oriented connection technologies from clamping-yoke screw connections to PUSH IN spring cage connections in all relevant cross-sectional areas

Universal use in all standard pitch sizes from 3.50 mm

A wide product range of reflow suitable products for automated SMT processes

Compact and multi-layer designs with up to 72 poles

#### Connectors

36 connections at 3.50 mm pitch, highest power reserves with 3.81 mm pitch and the largest application area in 5.08 mm pitch

Application oriented connections from clamping-yoke screw connections to PUSH IN spring cage connections

A wide product range of reflow suitable products for automated SMT processes

Multi-row and multi-layer designs with up to 48 poles

#### Circuit and Surge Protection

#### Terminal blocks

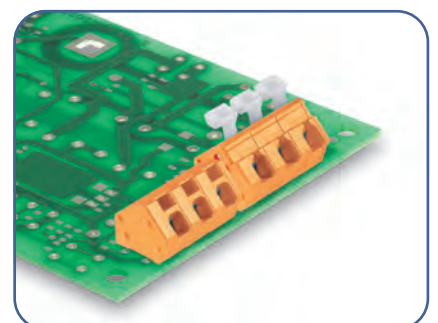
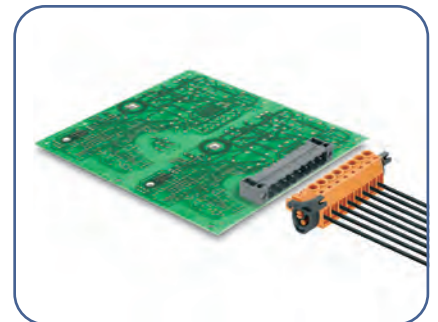

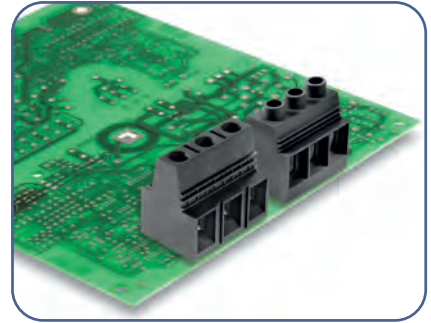
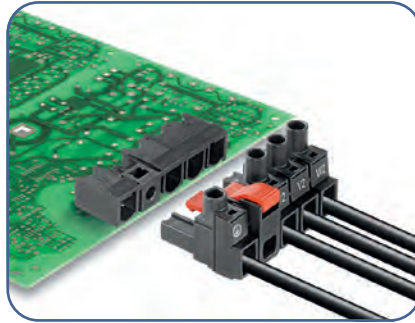
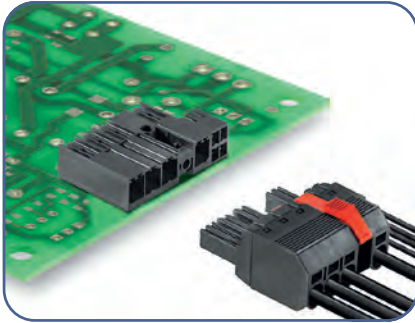

### OMNIMATE Power PCB: Terminals, Connectors & Feedthrough Terminals

#### Terminals

Heavy-duty up to 150 A / 1000 V (IEC) or 127 A / 600 V (UL)

Application-oriented scalability with connection cross sections from 16 mm<sup>2</sup> to 50 mm<sup>2</sup>

Simple approval of the devices up to 600 V (UL)

Maintenance-free steel clamping yoke for vibration resistant screw connections

#### Connectors

Application-oriented scalability: from compact 4 mm<sup>2</sup> connections for 29 A (IEC) or 20 A (UL) up to sturdy 16 mm<sup>2</sup> connections for 76 A (IEC) or 54 A (UL)

Unrestricted use up to 1000 V (IEC) or 600 V (UL)

Various application-optimised mounting options

#### Feedthrough Terminals

OMNIMATE Power :

- Device feed-through terminals WGK "PUSH IN"
- Device feed-through terminal PGK 4

#### OMNIMATE Housings PCB:

Component housings: Tailor-made suits straight off the rack

Small housings: The tailor-made solution for a wide application spectrum

Profile housings: The perfect solution for custom constructions and small-batch series

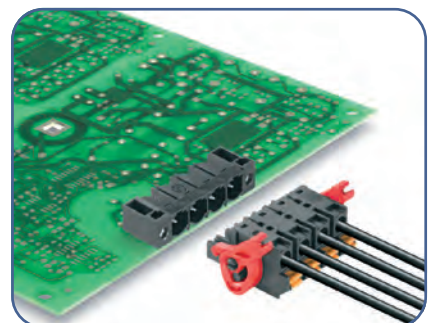
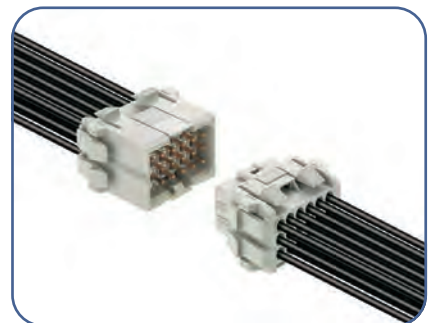

ELECTRIC SPECIALIST

- RF Coax Connectors
- Street Lighting Connectors
- DT Series connectors
- OSFP Connector
- ICCON Slim Power Pin
- AMP Power Series Connectors
- Circular Industrial
- CPC Connectors
- Dynamic Series Connectors & accessories
- Faston Electrical Quick Connects
- High Voltage Connectors (HEMS)
- HDC (Heavy Duty Connectors)
- LUMAWISE
- Metal Shell Micro Circular
- Micro MATE-N-LOK
- NECTOR M
- OSFP Connector
- Rings, Spades & Splices (AMPOWER, PIDG, PLASTI-GRIP...)
- RJ45
- Signal Double Lock
- Splice Products
- Terminals and Splices
- Timer
- Universal MATE-N-LOK
- Universal MATE-N-LOK II
- VAL-U-LOK



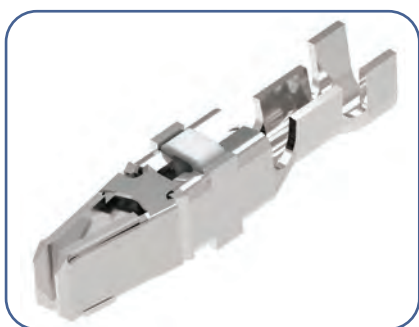
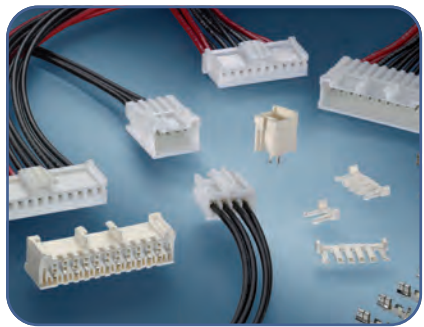
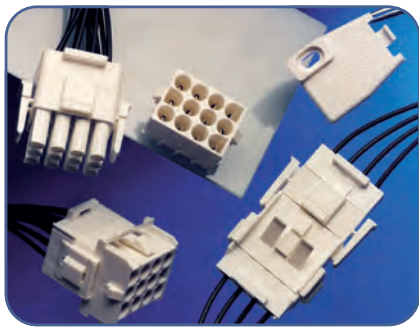
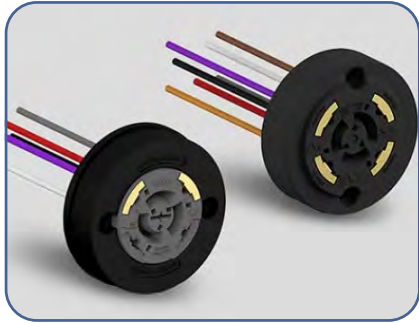





## RELAYS & CONTACTORS

Circuit Breakers

Aerospace, Ground Power and Industrial High Performance Contactors

Automotive Relays & Modules Data Sheets

Communication/Signal PC Board Relays

Contactors

High Performance Solid State Relays and Power Controllers

High Performance Time Delay Relays

High Voltage Relays

Latching/Bistable, Impulse, Rotary and Special Application Relays

Low Signal High Performance Relays

Mid-Range High Performance Relays

Mid-Range PC Board Relays

Plug-in/Panel Mount General Purpose Relays

Power PC Board Relays

Power Relays

Force Guided Contact Relays

Sensors & Protective Relays

Solid State Relays & Input/Output Modules

Time Delay Relays & Timing Modules





## CONNECTORS & CONNECTOR COMPONENTS

- Micro-Match Connectors
- .062" commercial pin & socket connector
- 1.5mm AMP mini CT connectors
- 2.16 IDC connectors
- 3mm centerline, micro MATE-N-LOK
- 4.2mm AMP-DUAC
- AMP-EDGE
- AMP-LATCH
- AMPLIVAR
- AMPMODU (Board-to-Board & Wire-to-Board)
- AMPMODU Crimp
- Backplane & Midplane
- Card Edge connectors
- CHAMP connectors
- Connectors & Backshells
- Consumer interconnects
- CORCOM Filters
- D-Subminiature connectors
- Economy Power Connectors
- FLEXSTRIP jumpers
- FPC connectors
- High speed Input/Output
- LCEDI connectors
- M series connectors
- METRIMATE
- Mezzanine connectors
- MIC (Multiple Interlock Connectors)
- Mini\_CT
- Mini-SAS
- Modular Jacks & Plugs
- MTA SL156
- Multi Beam
- Multimate contacts
- Power Triple Lock
- Pulso lock connectors and contacts
- RF/Coax
- Rits
- SAS connectors
- SATA connectors
- Sealed automotive
- Sealed industrial
- Socket /card products
- Solder Cup HD20
- Standard Timer (Rast 5 appliance)
- STRADA Whisper
- Universal Power

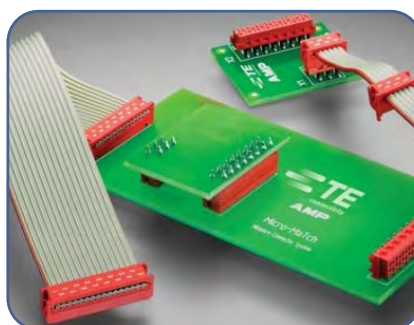
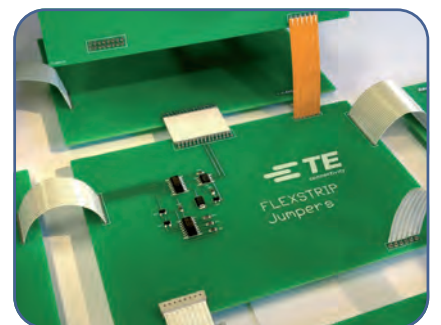
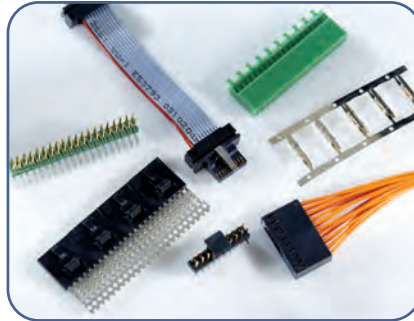

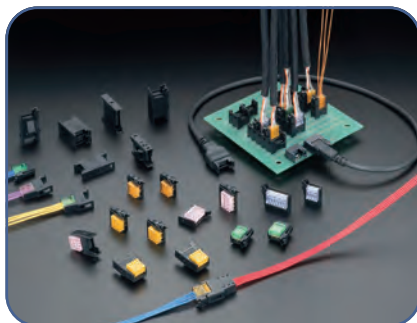
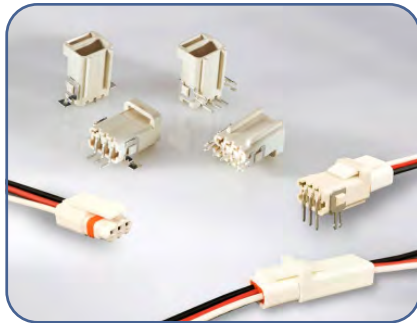
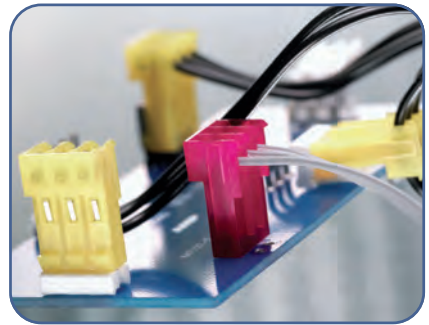
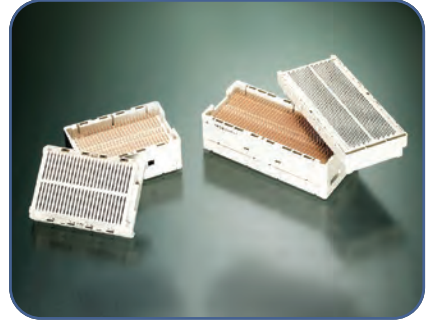
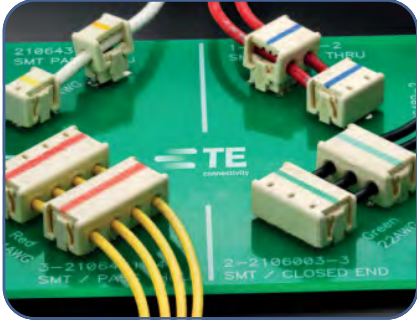



CROMPTON INSTRUMENTS

Power Measurement,  
Protection and Control

Integra Digital Metering  
Systems

Integra and Paladin  
Transducers

kWh Meters

Protector Trip Relays

Analogue Instruments

Current Transformers

Meter Relays and Digital  
Indicators

Shunts

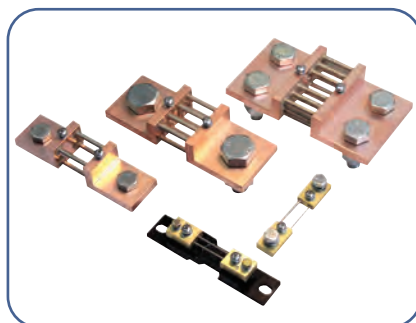

APPLICATION TOOLING

- OCEAN Applicators
- Crimp Quality Monitoring II
- Hand Tools
- Heat Shrink Equipment
- IDC/FFC Machines
- Magnet Wire Machines
- Pin Insertion Machines
- Press Fit Machines
- Testers
- Bench Terminators
- Used & reconditioned Machines
- Wire Preparation Machines
- Insertion and Extraction tools

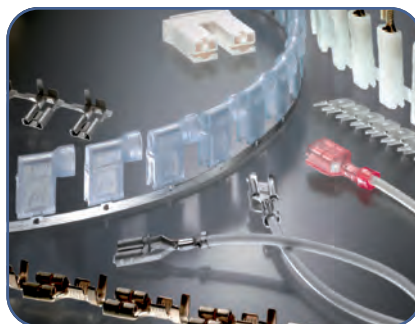



## IDENTIFICATION AND LABELING

### CABLE & WIRE ID

Blank Markers

Heat Shrink Markers and Sleeves

Pre-Printed Markers



### LABELS

Blank Labels

Icon Wheels

Label Accessories

Pre-Printed Labels



### MARKING & CAUTION TAPE

Caution & Hazard

Colour Marking

Dot & Arrow

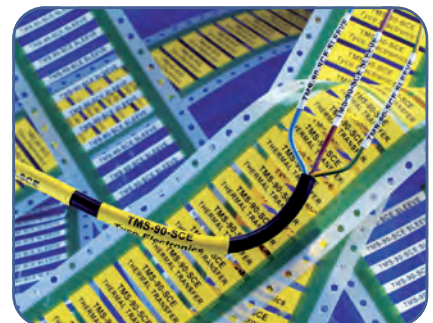
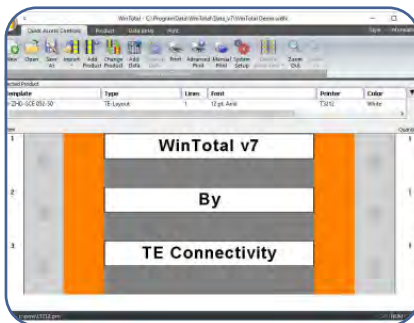

### PRINTERS & SOFTWARE

Identification Printer Software

Identification Printers

Printer Accessories

Ribbons



ENERGY

Raychem - MEDIUM AND HIGH VOLTAGE PRODUCTS

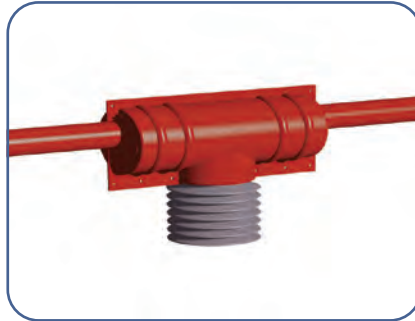

Breaker Bushings

Conductor and Leads

Disconnect Switches

Bus Support Insulators

Recloser Apparatus

Fuse Cutouts

Bus Bars

Lightning Arresters

Distribution Insulators

Transformer Bushings



APPLICATIONS

Mining

Nuclear power plants

OEMs

Overhead distribution

Petrochemical plants

Railways

Street lighting

Substations

Transmission lines

Underground distribution

Windfarms

Solar

Hydroelectric





HARNESSING



ADHESIVES AND SEALANTS

Epoxy

Fusion Tape

Hot Melt Tape

Repair Tape

Sealants



CONVOLUTED TUBING

HARNWARE SOFTWARE

HEAT SHRINK TUBING

HEAT SHRINK COMPONENTS

Accessories

Breakouts/Transitions

Cable Entry Seal

D-Sub Connector Boots

EMI Shielded Boots

End Caps

Feedthroughs & Cable Entry Seals

Heat Shrink Kits

Heat Shrink Marker Sleeves

Heat shrink Boots

Sealing & Repair Sleeves

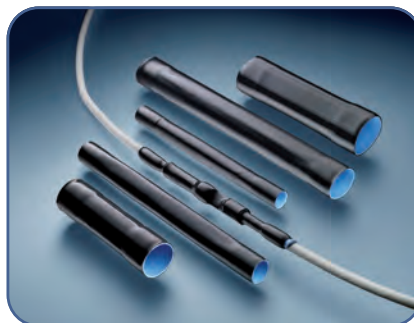

INTERCONNECT DEVICES

Coax Cable Termination

Discrete Wire Terminators

Shielded Contacts

SolderSleeve Shield

Terminators



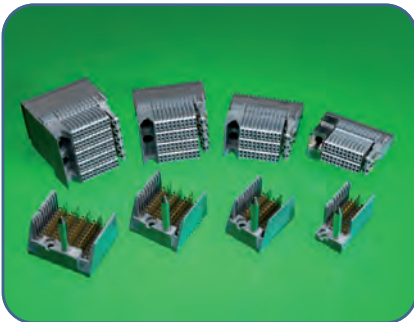
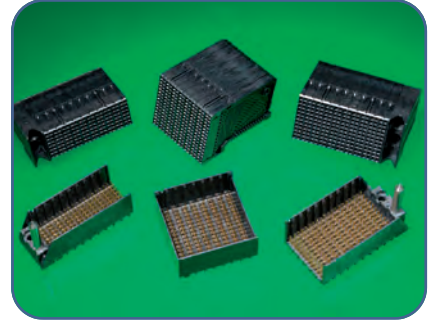
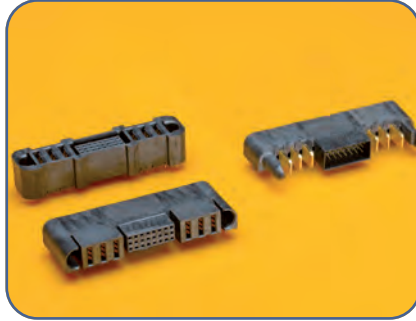
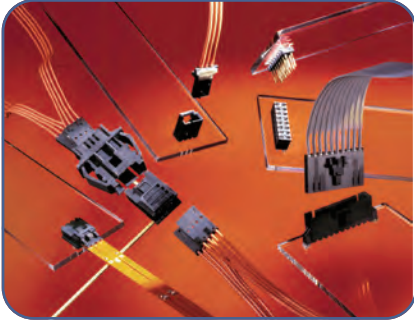

## BOARD-TO-BOARD

Board-to-Board High Speed

Board-to-Board Microminiature

Board-to-Board Power

Board-to-Board Signal

Board-to-Board Storage

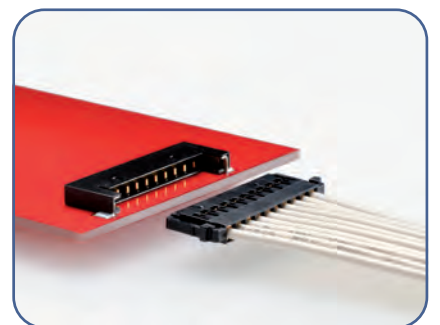
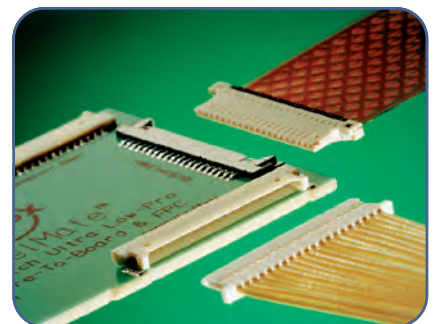
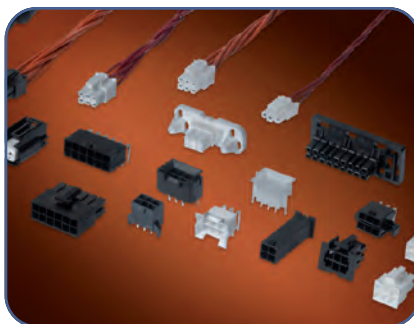
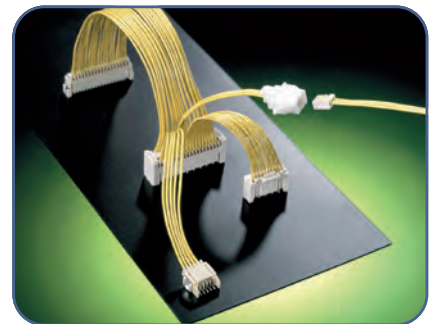
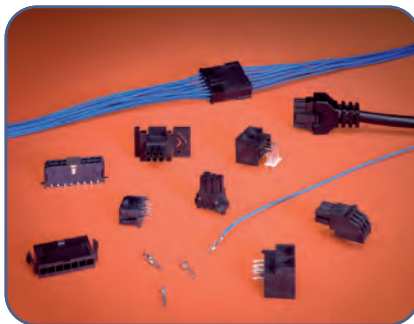
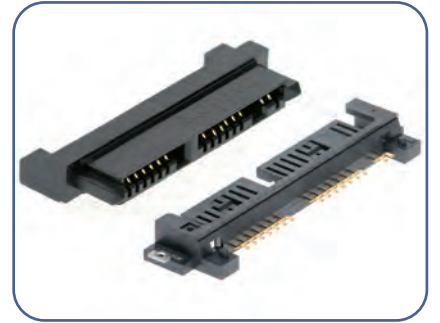
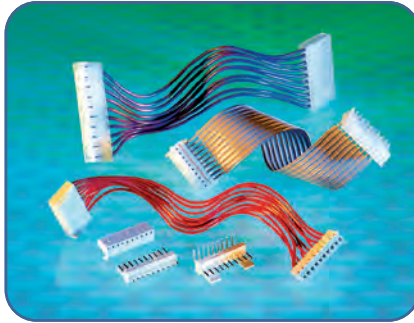

WIRE-TO-BOARD

- Wire-to-Board Microminiature
- Wire-to-Board Signal
- Wire-to-Board Power
- Wire-to-Board Ribbon Cable/  
Wire Trap
- Wire-to-Board Storage

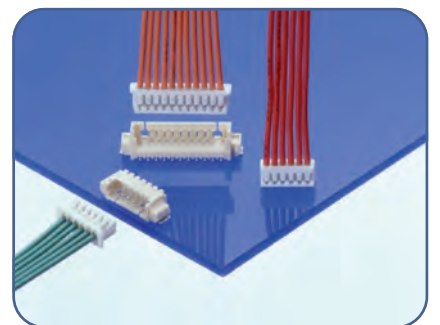

I/O CONNECTORS

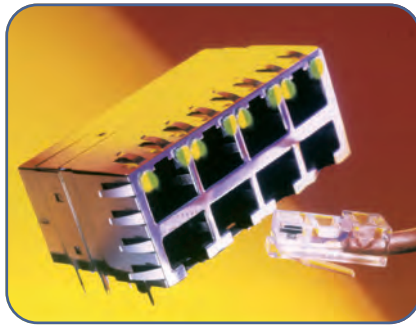
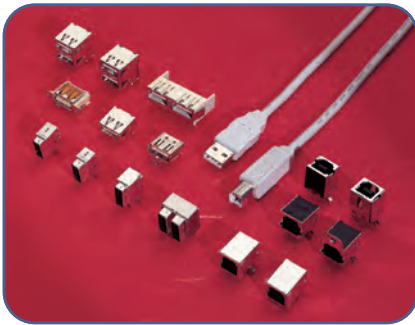

MEMORY MODULE  
SOCKETS





SEALED CONNECTORS



SOLID STATE LIGHTING

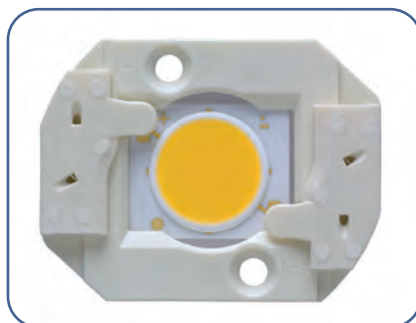



WIRE-TO-WIRE

Wire-to-Wire Power

Wire-to-Wire Signal

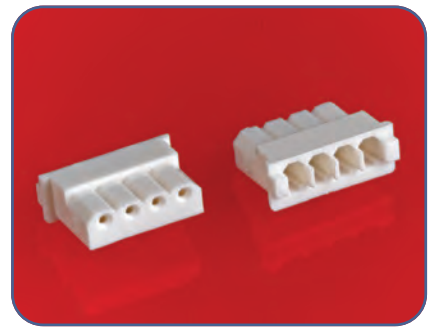
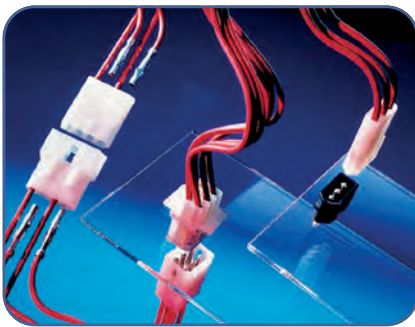
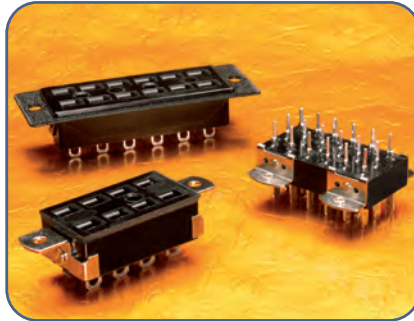

POWER CONNECTORS

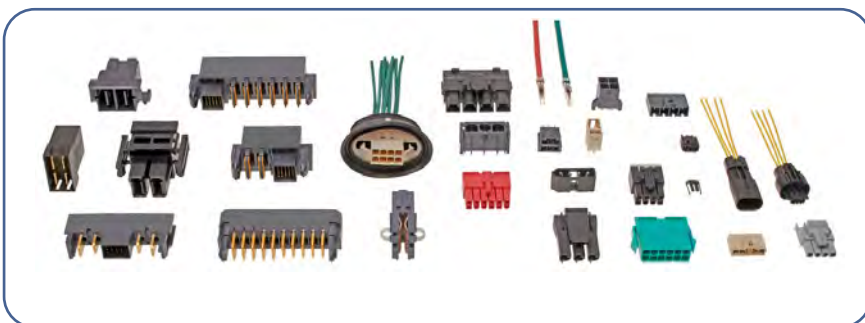
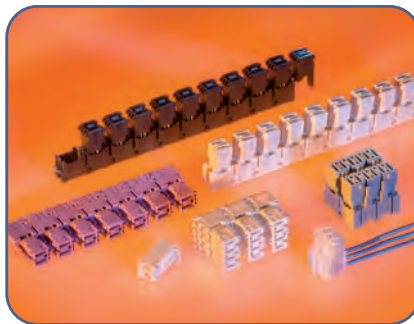



MEMORY CARD SOCKETS

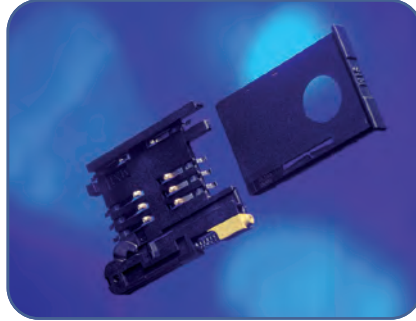

MODULAR JACKS

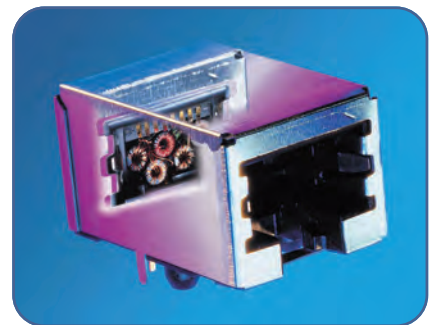
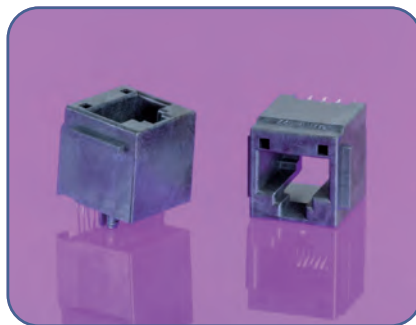

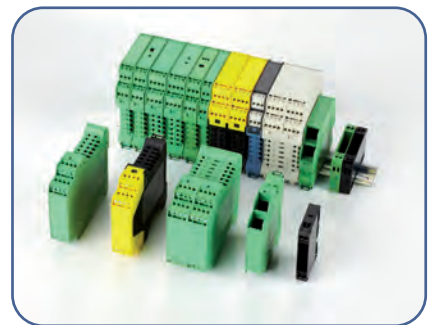
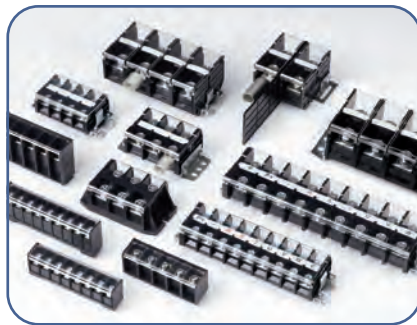
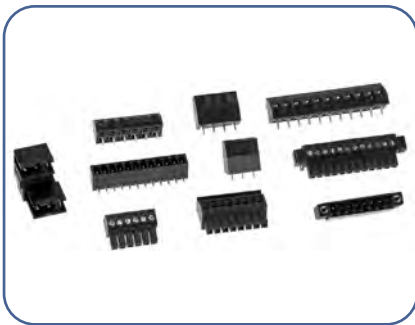
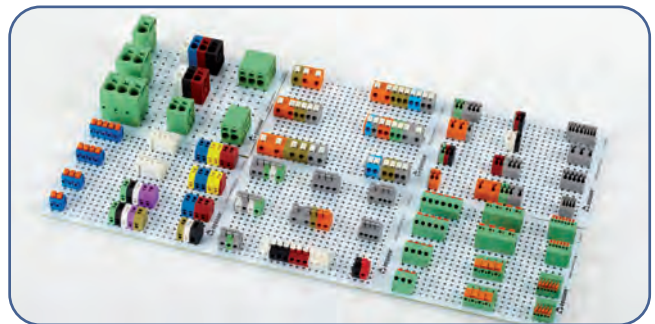
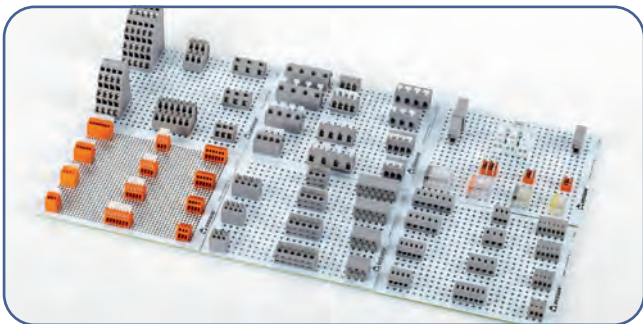
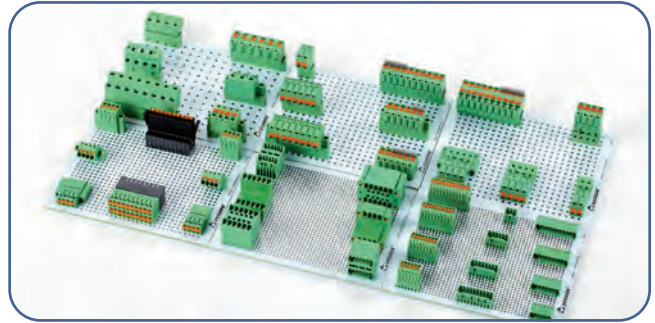
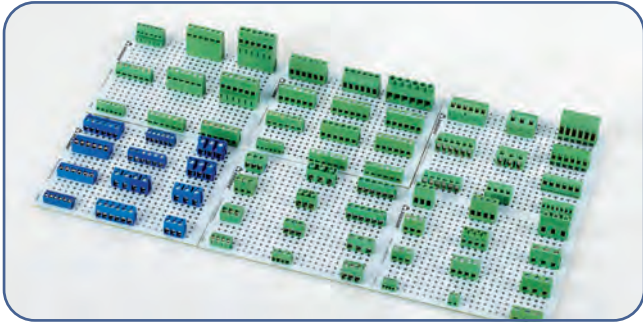

Plug-in Terminal Block

PCB Screw Terminal Block

Transformer Terminal Block

PCB Spring Terminal Block

Feed Through Terminal Block

Barrier Terminal Block



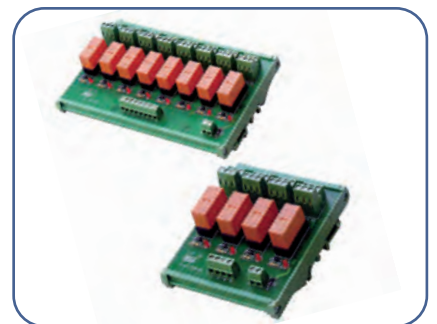

Vandal Resistant Switches

ø22A20 Switch

Compact Pushbuttons ø16 & ø22

Ø16ADX Switch

Limit Switch

CAM Switch

IDC Connector Module

D-SUB Connector Module

Relay Module

Float Level Switch

Safety Meter

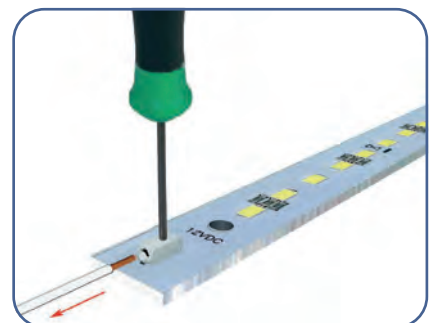
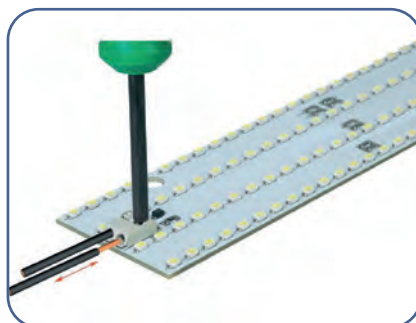



FLATWIRE INDUCTORS-  
FACCF

AC/DC CONVERTER-ASQ

DIN RAIL POWER SUPPLY-IS

LED DRIVERS

MiBuilt in type

Plastic housing external  
enhanced & slim type

Metal housing built-in slim type

American gauges

120-277/ 120-347 / 347-480

POWER SUPPLIES

DIN rail power supply (IS series)





LIGHTING CONTROL SYSTEM

RGBW/Y Controller  
RF&WIFI RGB&CCT

LED DIMMER

1-10V DIMMER

Sensor Dimmer & Switch

DMX DECODER

RF/WIFI/BLUETOOTH/IN-WALL



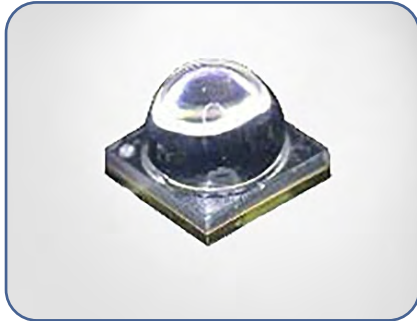

TACHAI INDUSTRIAL

INCANDESCENT

Vehicle Filament Wedge Lamp

T5mm, T5.8, T6.5, T13, T10mm, T15

Festoon Lamps

T6, T10



NEON LAMP

Neon Glow

Neon & Resistors

Neon Assembly

Base Neon

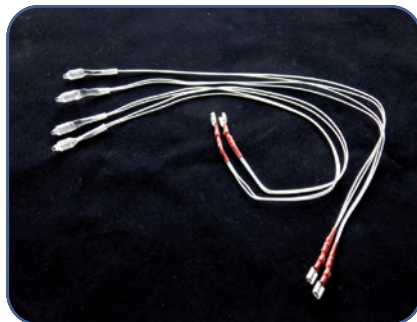

LED INDICATOR

AC/DC Solid LED

AC/DC Base LED

Lens LED



GAMING LIGHT

LED Push Button

205mm T5 LED TUBE

357mm T8 LED TUBE

LED Lights for Gaming Machines



**SCHRACK TECHNIK**

- Cam Switches
- Charge station
- Circuit breaker
- Network cable
- Power supply
- Protective device
- Transformer



KHONS

Portable electric vehicle charger

Electric vehicle charger with screen

Electric charger support connector

Inlet

Hybrid connector





EV Connectors and Chargers  
Panel charger  
Wall charger  
Cables  
Connector  
Hybrid inlet



# SYSTEMS



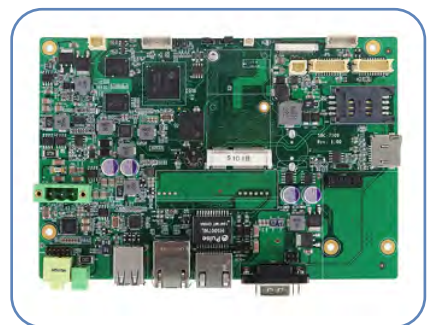
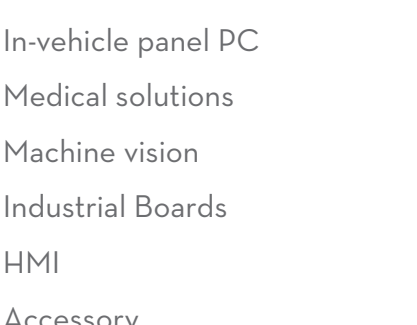
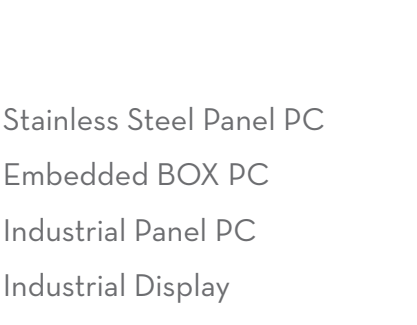

- Stainless Steel Panel PC
- Embedded BOX PC
- Industrial Panel PC
- Industrial Display
- HMI
- In-vehicle panel PC
- Medical solutions
- Machine vision
- Industrial Boards
- HMI
- Accessory

VR VIDEO

Open Frame

Bar Display

TFT+HDMI Board

TFT+Heater (Suitable for low temperature)

LCM

Character

Graphic

Others

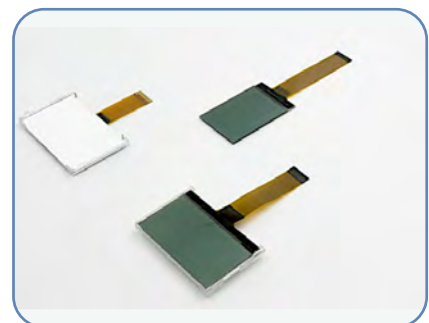
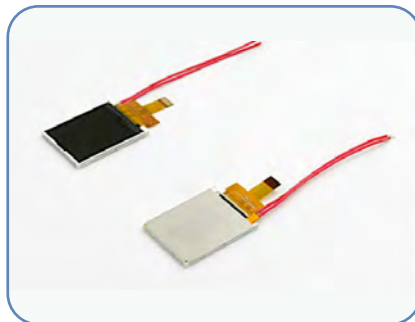
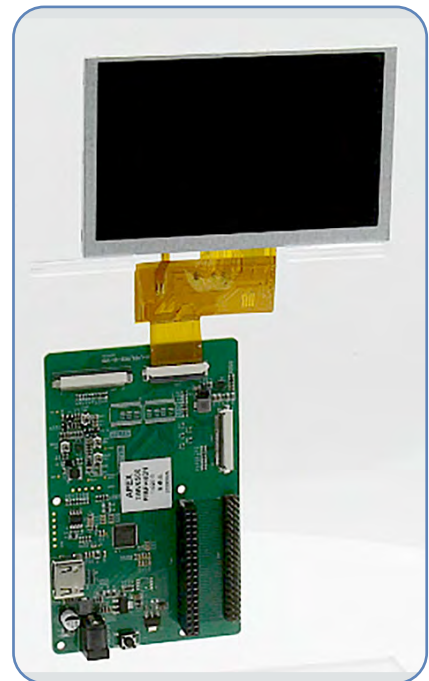

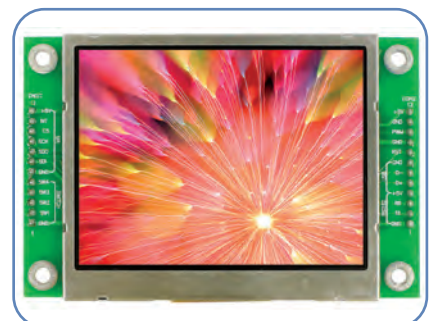
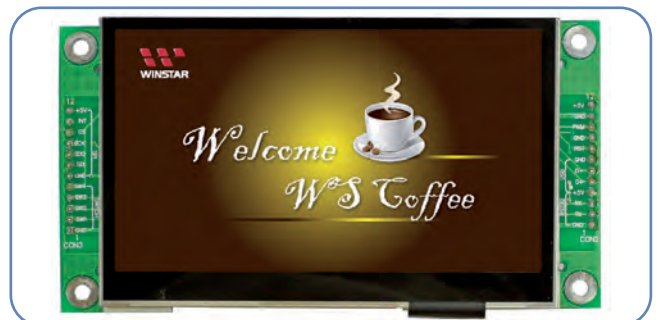
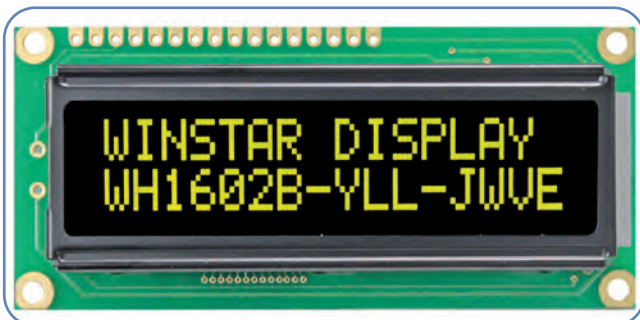
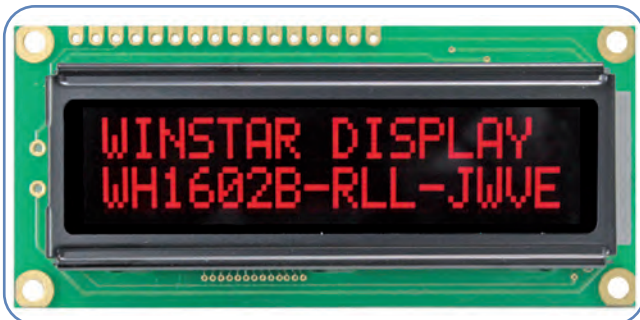
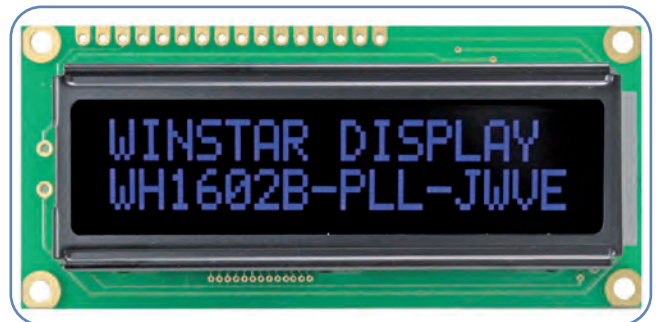
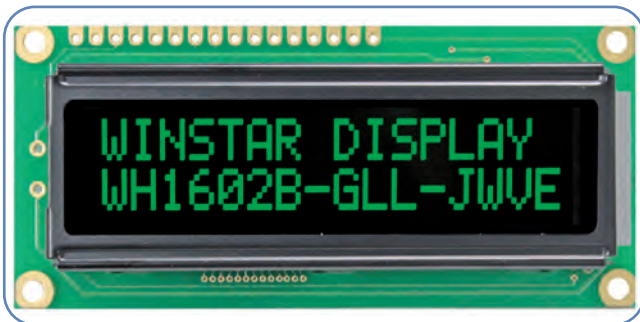

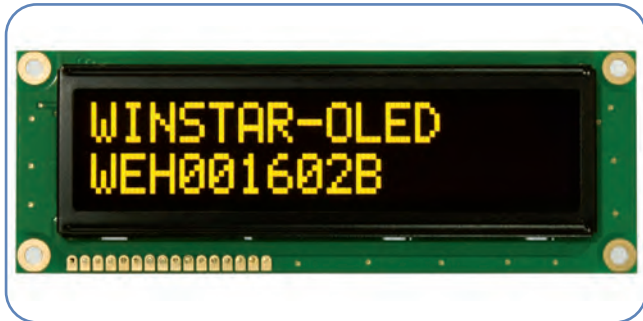

### TFT LCD DISPLAY

- Standard TFT (1.77" a 104")
- TFT+controller board
- IPS TFT LCD
- TFT LCD for HDMI signal
- High Brightness TFT Display
- Bar type TFT LCD
- Wide Temp TFT
- Monochrome TFT LCD
- Touch Panel

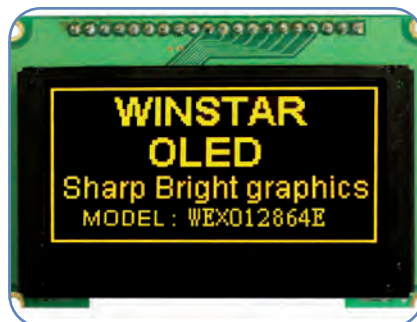
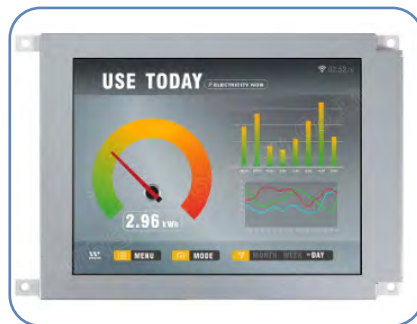

### OLED DISPLAY

- Graphic OLED Display
- Character OLED Display
- OLED touch Display
- OLED Knob



### LCD DISPLAY

- Graphic LCD
- Character LCD
- VATN LCD
- FSC LCD



### STN DISPLAY

- TN/HTN, STN, FSTN,
- DFSTN, ASTN, VATN
- TECHNOLOGY

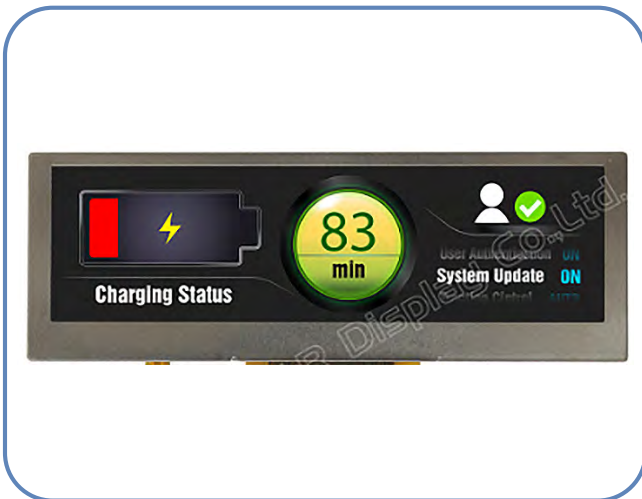

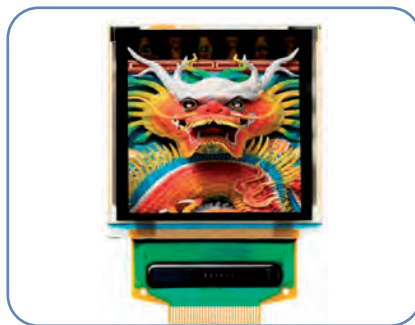
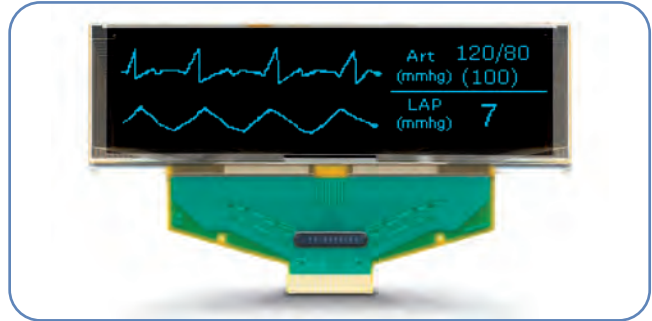
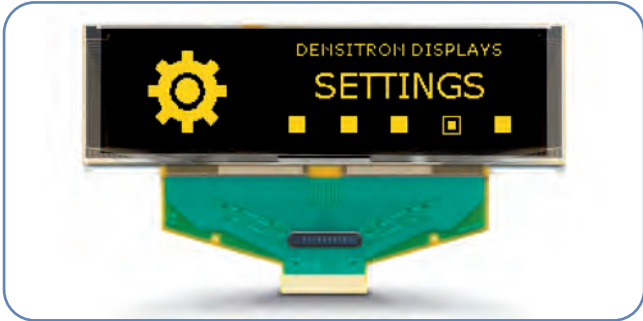

- Optical Bonding
- GUI Design Tools
- RipDraw Product Suite
- Discover EDS here
- Engineering Design
- OLEDs
- TFTs
- Monochrome
- Touch Panels
- Low Power



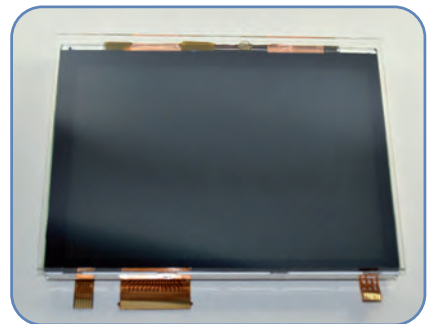

DEVETECH  
TOUCHSCREENS & TFT

Color FTF LCD Modules 1.44”  
to 10,1”

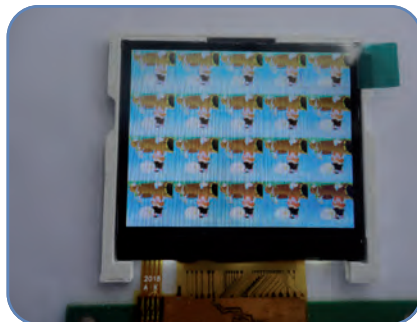

TouchScreens:

4WireTouch S-Series (Standard  
1.8”-22”)

5WireTouch S-Series (Standard  
12”-22”)

SAW Touch S-Series (Standard  
6.4”-47”)

IR Touch NF-Series  
(No Frame 15”-19”)

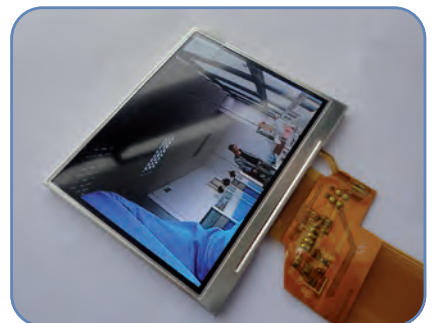
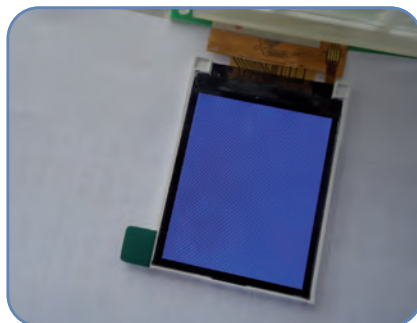

MutiTouchScreens:

15” to 150” S-Series Dual-  
Touchscreen

IR Touch A-Series  
(Aluminium 17”-150”)

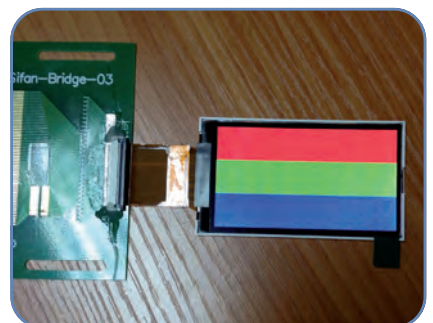
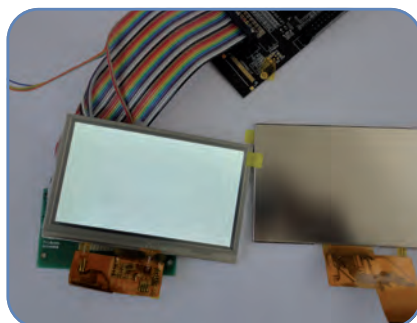

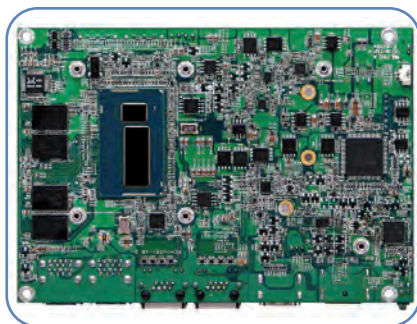
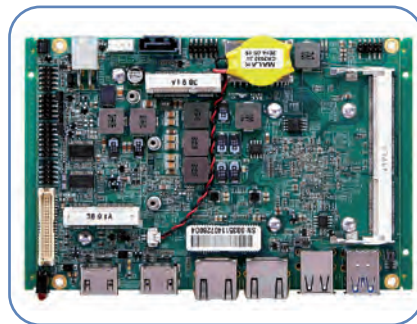
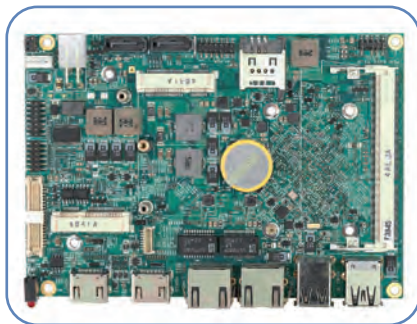
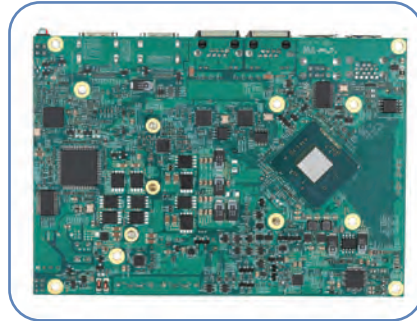

DEVETECH INDUSTRIAL  
COMPUTERS

BOARD

2.5" SERIES

3.5" SERIES

ARM SERIES

CPCI SERIES

IPC

IPC ACCESSORIES





OPENFRAME  
TOUCHSCREENS

- Standard-Aspect Ratio
- 12" TouchPro PCAP
- 15" AccuTouch / PCAP/  
SecureTouch
- 17" Accu Touch / PCAP
- 19" / 21.5" / 23.8" / 32" / 43"  
PCAP
- Wide-Aspect Ratio
- 10.1" / 15.6" / 21.5" / 23.8" /  
27" PCAP
- Large Format Wide-Aspect  
Ratio
- 31.5" / 42.5" PCAP

TOUCHSCREEN DISPLAY  
MODULES

- 7" & 10.1" & 15.6" TouchPro  
(COF, USB, Multitouch up to  
10, LVDS)



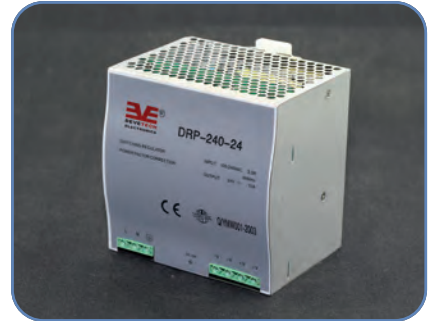

**POWER SUPPLY**

Single output switching power supply

Dual output switching power supply

Triple output switching power supply

Quad output switching power supply

Din rail switching power supply

NE single output switching power supply

Water-proof switching power supply

Rain-proof switching power supply

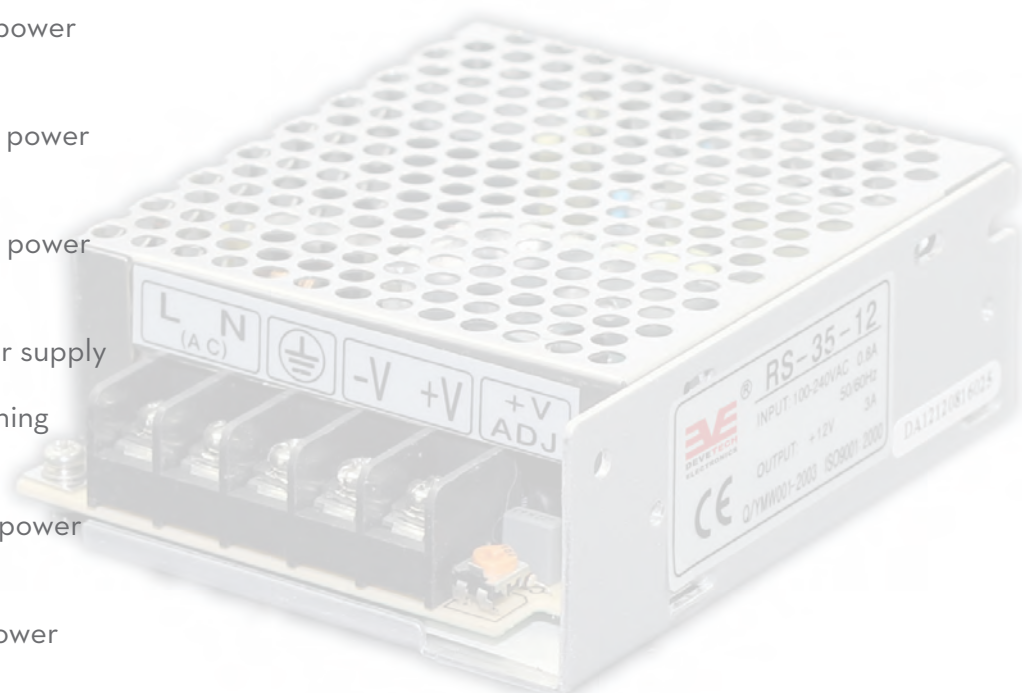

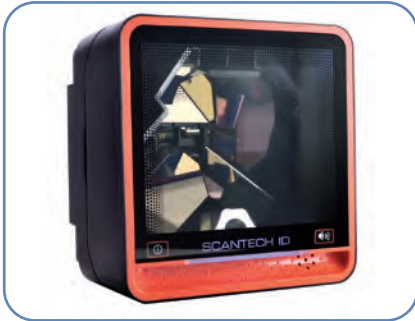

SCANNERS

- Price Checkers / Scan Kiosks
- Desktop / In-Counter Scanners
- Handheld Linear Imager Scanners
- Handheld Laser / 2D Scanners
- Handheld Area Imager Scanners
- Modules / Fixed Mount Scanners
- Magnetic / Barcode Slot Readers
- Pen Scanners
- RFID Solutions
- Pocket scanners





CCTV

HD-SDI SYSTEM

AHD CAMERA

3D-DNR CAMERA

WDR CAMERA

IR LED CAMERA

BULLET CAMERA

STANDARD CAMERA

DOME CAMERA

MINIATURE CAMERA

CCD BOARD CAMERA

PTZ (pan/tilt/zoom)

IP CAMERA & NVR

ZOOM CAMERA

USB CAMERA

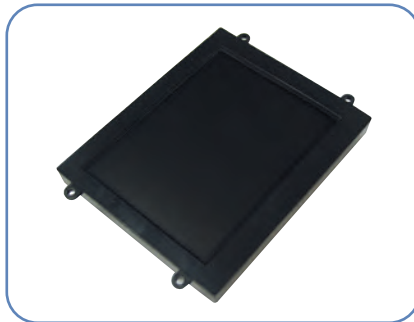
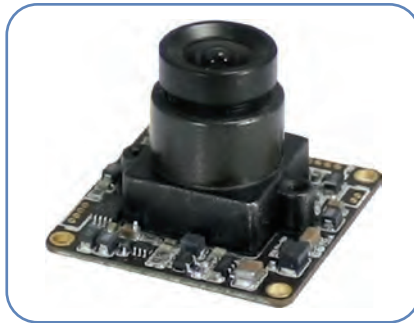

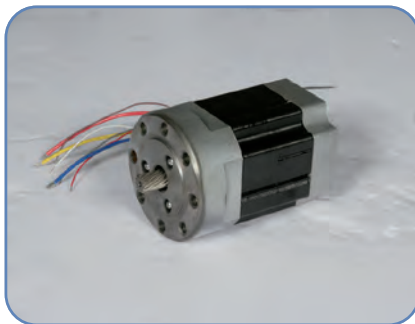
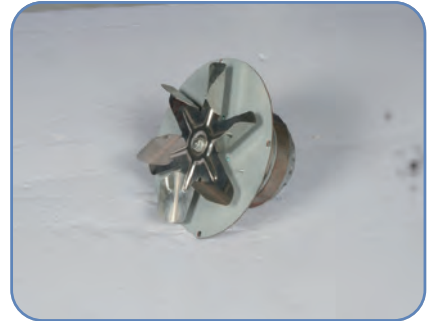
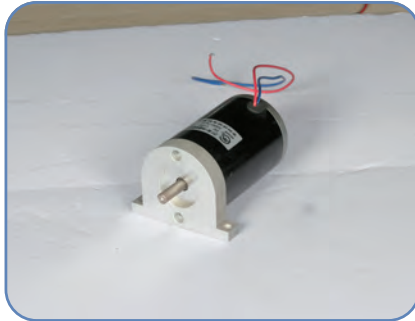

DEVETECH MOTORS

AC Motor



DC Brush Motor



DC Brushless Motor

Centrifugal

Axial

CrossFlow Blowers

Precision Fan

ISO9001-2008

ISO 14001-2004

TS16949

CE, UL, VDE, TÜV, CCC





ADAPTERS

- USB Power Adapter
- Mini USB Charger
  - Single USB Charger



- Wall Mount Adapter
- 6W Series
  - 15W Series
  - 24W Series
  - 36W Series



Multi-Plug Adapter

- Desktop Adapter
- 18W Series
  - 24W Series
  - 36W Series
  - 48W Series
  - 65W Series
  - 72W Series
  - 96W Series
  - 120W Series



DEVETECH CABLES & USB HUBS



SVGA CABLE

SVGA to USB cable

SVGA to HDMI cable

Gold-plated SVGA with filter

SVGA to Scart Cable

DB9 FF

DB25 to CN36

DB25 to DB9F

DB25 to DB25

CUSTOMIZED CABLES



HDMI CABLE

HDMI to Micro HDMI

Metal Flat HDMI

Flat HDMI

LED HDMI

360° HDMI Cable

HDMI to DVI

CUSTOMIZED CABLES



USB 3.0 AND 2.0 CABLE

USB3.0 AM TO BM

USB3.0 TO MICRO

USB3.0 TO AM

USB3.0 AM TO AF

FLAT AM AF

FLAT AM MICRO

USB2.0 AM TO RS232

CUSTOMIZED CABLES



ALL TYPES OF CUSTOMIZED CABLES



## YDLIDAR SENSORS

Triangulation

ToF

Solid-State

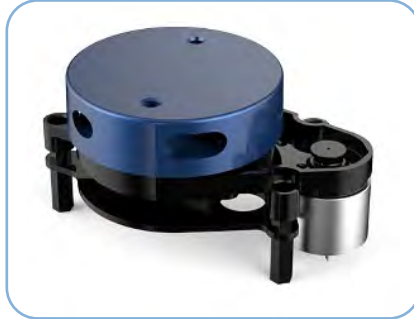





- Open Frame Monitors
- Touch display Monitors
- Desktop Touch Monitors
- Panel PC/All in-one
- Box PC /Industrial
- Embedded PC
- Medical Monitors

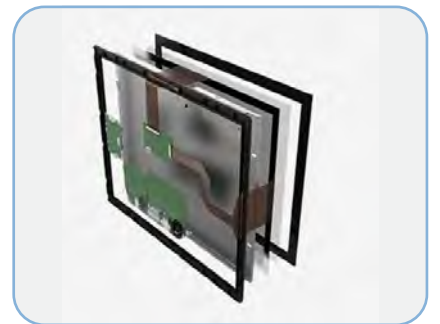

-EMBEDDED BOARD

System on Module / SBC /

ITX

- INDUSTRIAL PANEL

PC

Panel PC / HMI / Open

Frame / LCD

- BOX PC

Mini PC / ICE-104

- PERIPHERAL

Peripheral

- STORAGE

M2 Storage

mPCIe DOM

SATA DOM

IDE DOM

CF Card

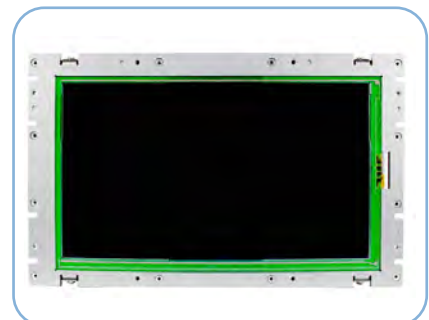
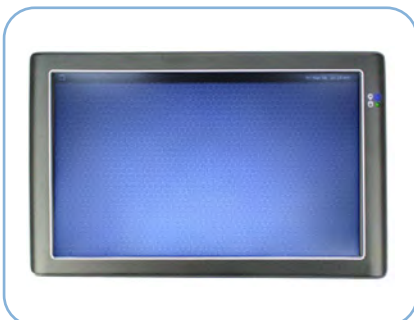
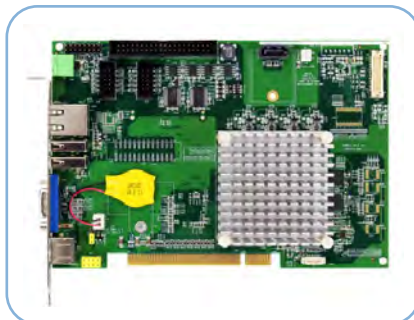
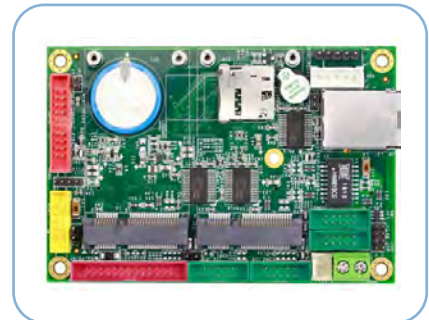
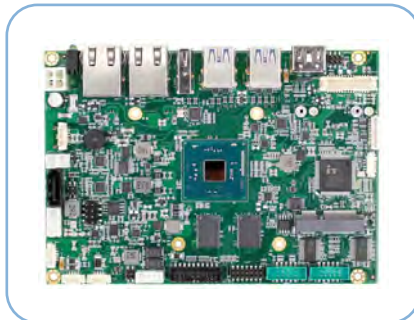



-SINGLE BOARD COMPUTER

SBC 3.5"

SBC 2.5" (Pico-ITX)

EPIC

Mini ITX

-INDUSTRIAL MOTHER

BOARD

Mini ITX

ATX

-INDUSTRIAL COMPUTER

Flex

Tran

Wind

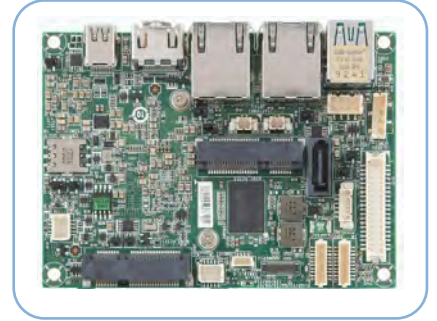

DEGSON

EtherCAT IO protocol communication coupler

Digital I/O module PNP type

Analog I/O Module

Power module

Inserts

Contacts for Inserts

Housings Inserts

Cable gland

Multifunctional Case

Hybrid inlet

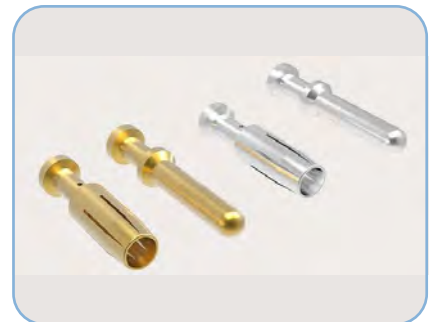



- Laser marking labels
- Metallic labels
- Static dissipation labels.
- Heat shrink markers
- Polyester labels
- Printers
- Aggressive adhesion labels
- Heat resistant labels

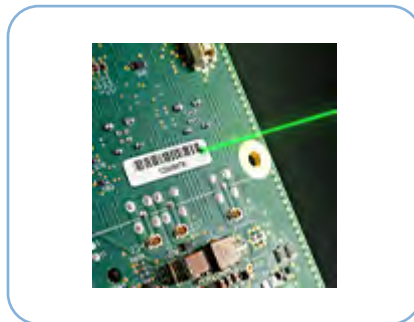





OPTICAL TRANSCEIVERS:  
Fiber Optical Transmission  
components for LANs, WANs,  
SANs, MANs & ANs

COPPER TRANSCEIVERS  
SFP-T

OSA: Optical Sub-Module  
Assembly for FTTX  
applications

OPTICAL EXTENDERS  
ACTIVE OPTICAL CABLE  
(AOC)

DIRECT ATTACH CABLE  
(DAC)



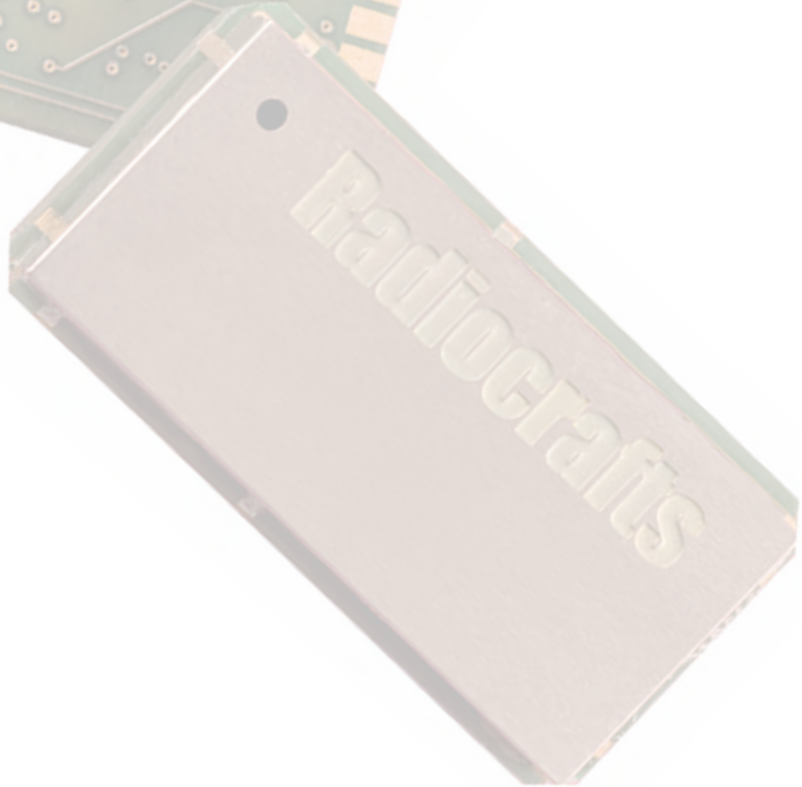
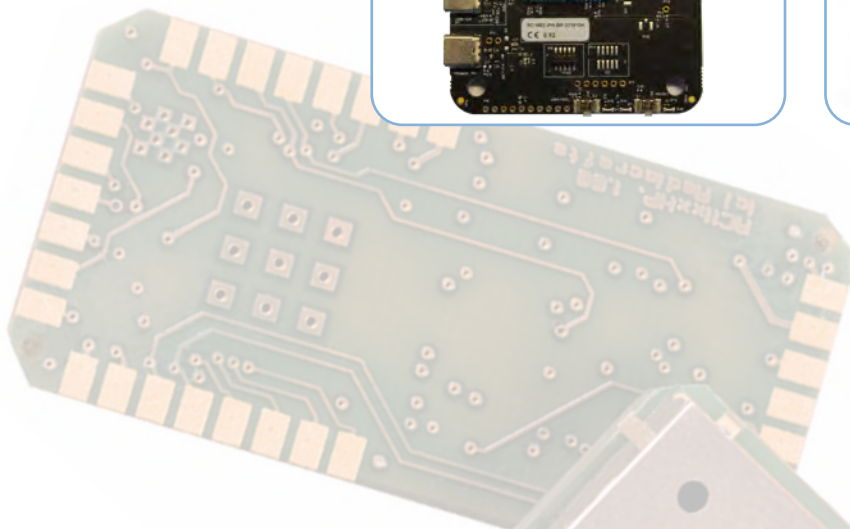
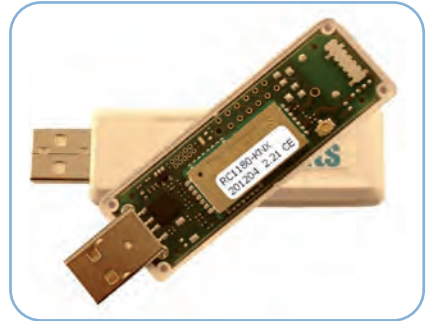

RF&WIRELESS MODULES

- MIoTY Network
- RIIM
- RIIoT
- Wireless M-Bus
- WIZE
- RC232
- TinyMesh
- SIGFOX
- ZigBee
- KNX-RF
- Customizable



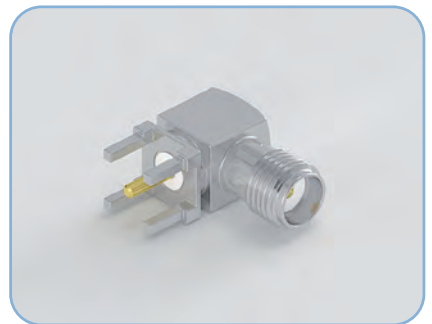
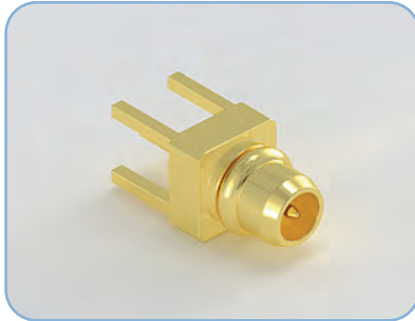

DEVETECH WIRELESS  
ACCESORIES, ANTENNAS  
AND CONNECTORS

RF connectors

Semi-rigid series

Semi-flexible series

Mini-coaxial series

RG/LMR/HDF series

Low-loss series

Indoor Ruber Antennas

Outdoor Directional Antennas

GPS + GSM Combo Antennas

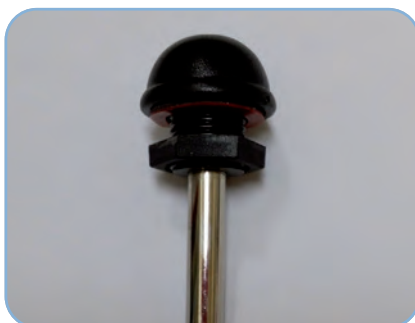

Certified by:

ISO 9001 ISO 14001 RoHS  
REACH IMDS PFOA PFOS  
ODS

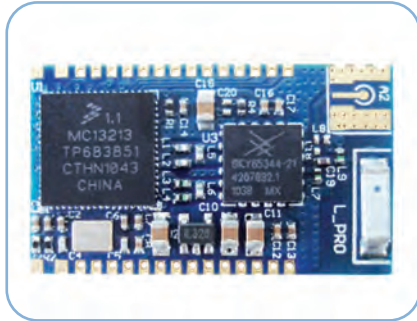
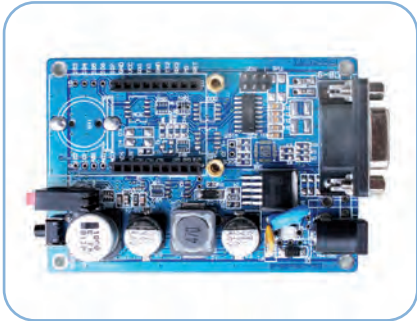

WIRELESS TECHNOLOGY

- ZigBee
- GPRS
- Wi-Fi
- Sub 1Ghz
- Smart Lighting
- Smart Home



ANTENNAS

5G /4G LTE/ WIFI

3G GSM / 868 MHz/

433MHz / 915MHz/

MIMO /GPS/GLONASS

GALILEO/ GNSS /

Omni / Marine /

Direction Wall Mount





A series of horizontal dotted lines spanning the width of the page, intended for writing notes.



A series of horizontal dotted lines spanning the width of the page, intended for writing notes.



A series of horizontal dotted lines spanning the width of the page, intended for writing notes.



A series of horizontal dotted lines spanning the width of the page, intended for writing notes.



A series of horizontal dotted lines for writing notes.





A series of horizontal dotted lines spanning the width of the page, intended for writing notes.



# DACHS

## BARCELONA

Pol. Ind. Els Garrofers  
Avda. del Progrés, 97  
08340 Vilassar de Mar  
(+34) **93 741 85 00**  
[barcelona@dachs.es](mailto:barcelona@dachs.es)

## MADRID

Pol. Ind. Los Olivos.  
C/ Progreso, 2.  
Edificio Bosque y Payá.  
Oficinas 15 y 17.  
28906 Getafe.  
(+34) **91 799 47 70**  
[madrid@dachs.es](mailto:madrid@dachs.es)

## BIZKAIA

Estartetxe, 5 · Dep. 219  
48940 Leioa  
(+34) **94 463 01 82**  
[norte@dachs.es](mailto:norte@dachs.es)

